

## **IMPORTANT SAFETY NOTICE**

Appropriate service methods and proper repair procedures are essential for the safe, reliable operation of all motor vehicles as well as the personal safety of the individual doing the work. This Manual provides general directions for accomplishing service and repair work with tested, effective techniques. Following them will help assure reliability.

There are numerous variations in procedures, techniques, tools and parts for servicing vehicles, as well as in the skill of the individual doing the work. This Manual cannot possibly anticipate all such variations and provide advice or cautions as to each. Accordingly, anyone who departs from the instructions provided in this Manual must first establish that he compromises neither his personal safety nor the vehicle integrity by his choice of methods, tools or parts.

## **NOTES, CAUTIONS, AND WARNINGS**

As you read through the procedures, you will come across NOTES, CAUTIONS, and WARNINGS. Each one is there for a specific purpose. NOTES give you added information that will help you to complete a particular procedure. CAUTIONS are given to prevent you from making an error that could damage the vehicle. WARNINGS remind you to be especially careful in those areas where carelessness can cause personal injury. The following list contains some general WARNINGS that you should follow when you work on a vehicle.

- Always wear safety glasses for eye protection.
- Use safety stands whenever a procedure requires you to be under the vehicle with the vehicle jacked up.
- Be sure that the ignition switch is always in the OFF position, unless otherwise required by the procedure.
- Set the parking brake when working on the vehicle. If you have an automatic transmission, set it in PARK unless instructed otherwise for a specific operation. If you have a manual transmission, it should be in REVERSE (engine OFF) or NEUTRAL (engine ON) unless instructed otherwise for a specific operation. Place wood blocks (4" x 4" or larger) to the front and rear surfaces of the tires to provide further restraint from inadvertent vehicle movement.
- Operate the engine only in a well-ventilated area to avoid the danger of carbon monoxide.
- Keep yourself and your clothing away from the moving parts, when the engine is running, especially the fan and drive belts.
- To prevent serious burns, avoid contact with hot metal parts such as the radiator, exhaust manifold, tail pipe, catalytic converter and muffler.
- Do not smoke while working on the vehicle.
- To avoid injury, always remove rings, watches, loose hanging jewelry, and loose clothing before beginning to work on a vehicle. Tie long hair securely behind the head.
- Keep hands and other objects clear of the radiator fan blades. Electric cooling fans can start to operate at any time by an increase in underhood temperatures, even though the ignition is in the OFF position. Therefore, care should be taken to ensure that the electric cooling fan is completely disconnected when working under the hood.
- Disconnect the negative battery ground cable before using any electric welding equipment.

# TREMEC TR-3550 AND TKO TRANSMISSIONS

## TABLE OF CONTENTS

## PAGE

Important Notice — Before You Begin Service.....	1
Identify Your Type of Tremec TR-3550 or Tremec TKO Transmission .....	1
Shifter Location Conversion Kits .....	1
Disassembled View Legend — Late Design And TKO .....	2
Disassembled View .....	3
Dissassembled View Legend .....	4-5
To Replace T-5 Transmission with Tremec TR-3550 or TKO High Performance Transmissions .....	6
Transmission Removal.....	6
Transmission Installation .....	7
Disassembly — Transmission.....	8-15
Disassembly and Assembly—Subassemblies	
Input Shaft Bearing .....	16
Countershaft (Cluster Gear) — Early One-Piece Design .....	16
Countershaft (Cluster Gear) — Late Three-Piece Design .....	17-18
Fifth Gear Synchronizer Assembly .....	19
Reverse Idler Assembly — Early and Late Designs.....	20-21
Output Shaft and Gear Assembly — Early and Late Designs .....	22-25
Synchronizer .....	26
Case Cover and Shifting Mechanism .....	26-28
Shifting Lugs .....	28
Extension Housing .....	29-30
Reverse Inhibitor Assembly .....	31
Extension Housing Rear Seal .....	32
Assembly — Transmission.....	33-40
Transmission Diagnosis .....	40-42
Inspection .....	43
Transmission Cleaning.....	43
Specifications .....	44
Metrics	
Introduction .....	45
Nomenclature for Bolts .....	45
Bolt Strength Identification .....	46
Hex Nut Strength Identification .....	46
Other Types of Parts .....	46
English/Metric Conversion .....	47
Decimal and Metric Equivalents .....	48
Torque Conversion .....	49

**IMPORTANT NOTICE—BEFORE YOU BEGIN SERVICE**

**IDENTIFY YOUR TYPE OF TREMEC TR-3550 OR TREMEC TKO TRANSMISSION**

This service manual covers the TR-3550 (#2600682) and TKO (#2600708) model Tremec Transmissions. The part number is located on an identification tag on the right side of the transmission. The following chart briefly describes differences in the TR-3550 and the TKO, as well as design changes that have been made since the transmissions were introduced. Disassembled views of these early and late design parts are located on pages 2-3. Before performing any service procedure, be sure to identify your Tremec Transmission.

COMPONENT	EARLY/LATE DESIGN	APPLICATION	
		TR-3550	TKO
Input Shaft	—	10 Splines	26 Splines
Main Output Shaft	—	28 Splines	31 Splines
Extension Housing - seal/bushing	—	Standard Dia.	Larger Dia.
Shift Lever (Short Throw)	—	Optional	Standard
Countershaft (Cluster Gears)	Early design is one-piece. Late design is three-piece.	Yes	Yes
Reverse Idler Gear Assembly	Late design—2 <sup>nd</sup> set of roller bearings added.	Yes	Yes
Shift Rails	Late design—Shift rail ramp angles revised. No change in cover.	Yes	Yes
Shift Selector Rails	Early design—Set screw retains finger/socket assy. Late design—Retained with roll pin.	Yes	Yes
Output Shaft (Mainshaft)	Early design—Spacers retain 3 <sup>rd</sup> and 1 <sup>st</sup> gear bearing cages. Late design—Retained with snap rings.	Yes	Yes

**SHIFTER LOCATION CONVERSION KITS**

Part Number	Shifter Kit	Application	Dimension
MU2671136	Front Shift Conversion Kit	TR-3550/TKO	178.20mm
MU2671127	Mid-Shift Conversion Kit	TR-3550/TKO	322.00mm

Two Shift Conversion Kits are available from Tremec to customize the shifter location for your vehicle. The standard dimension is 495.80mm from the front of the transmission to the centerline of the shifter for both Tremec TR-3550 and TKO models as shown in the illustration.

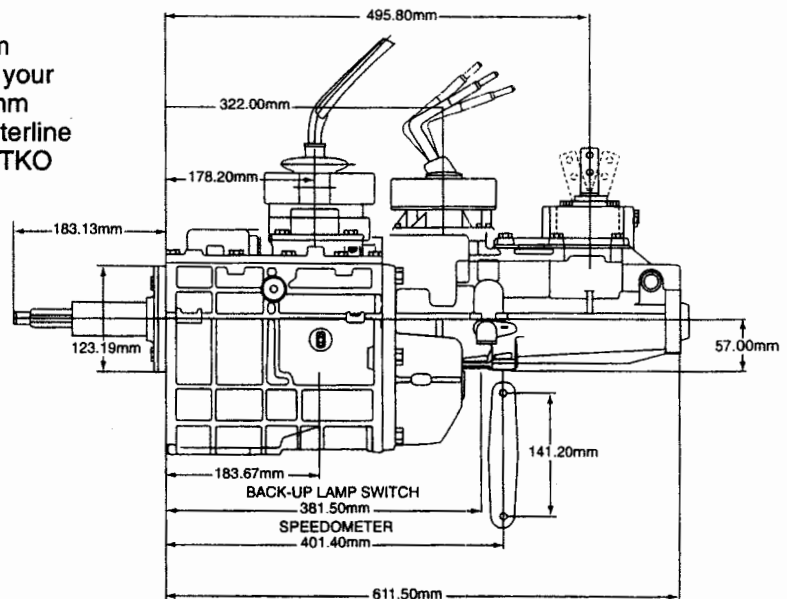
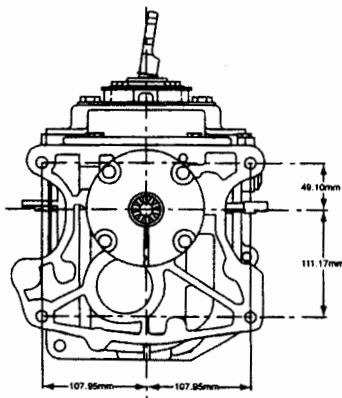

DISASSEMBLED VIEW LEGEND — LATE DESIGN AND TKO

LATE DESIGN COMPONENTS

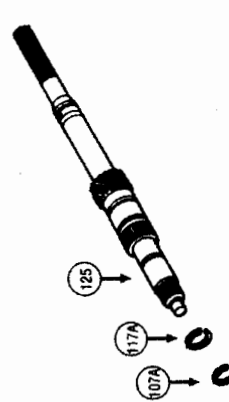
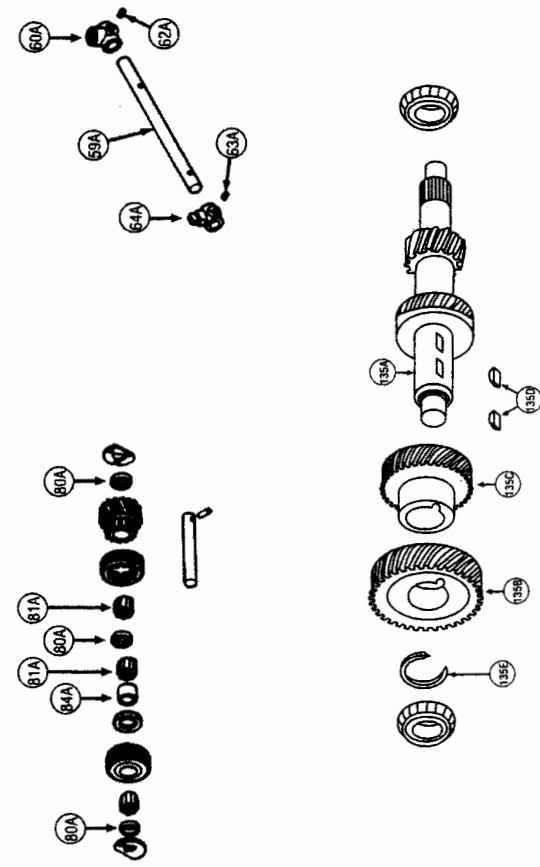
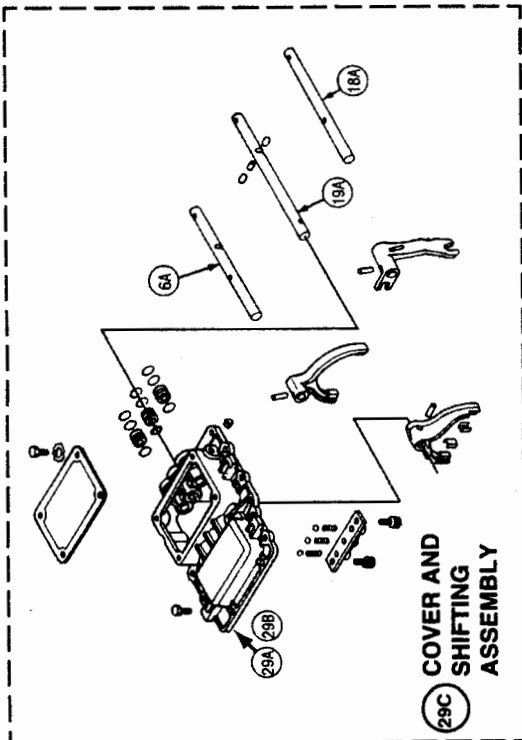

UNIQUE TKO MODEL COMPONENTS

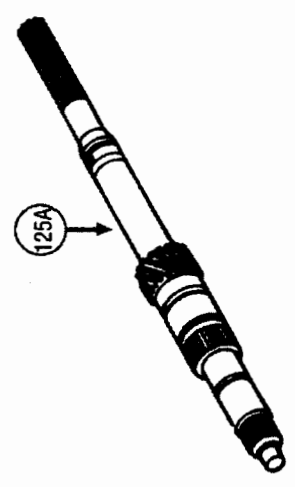
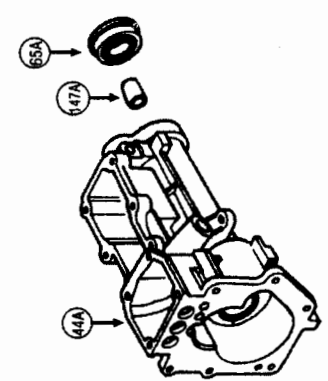

DISASSEMBLED VIEW

# SEE PAGE 2 FOR LATE-DESIGN COMPONENTS  
■ TKO MODEL USES UNIQUE PART — SEE PARTS LIST ON PAGES 4-5.

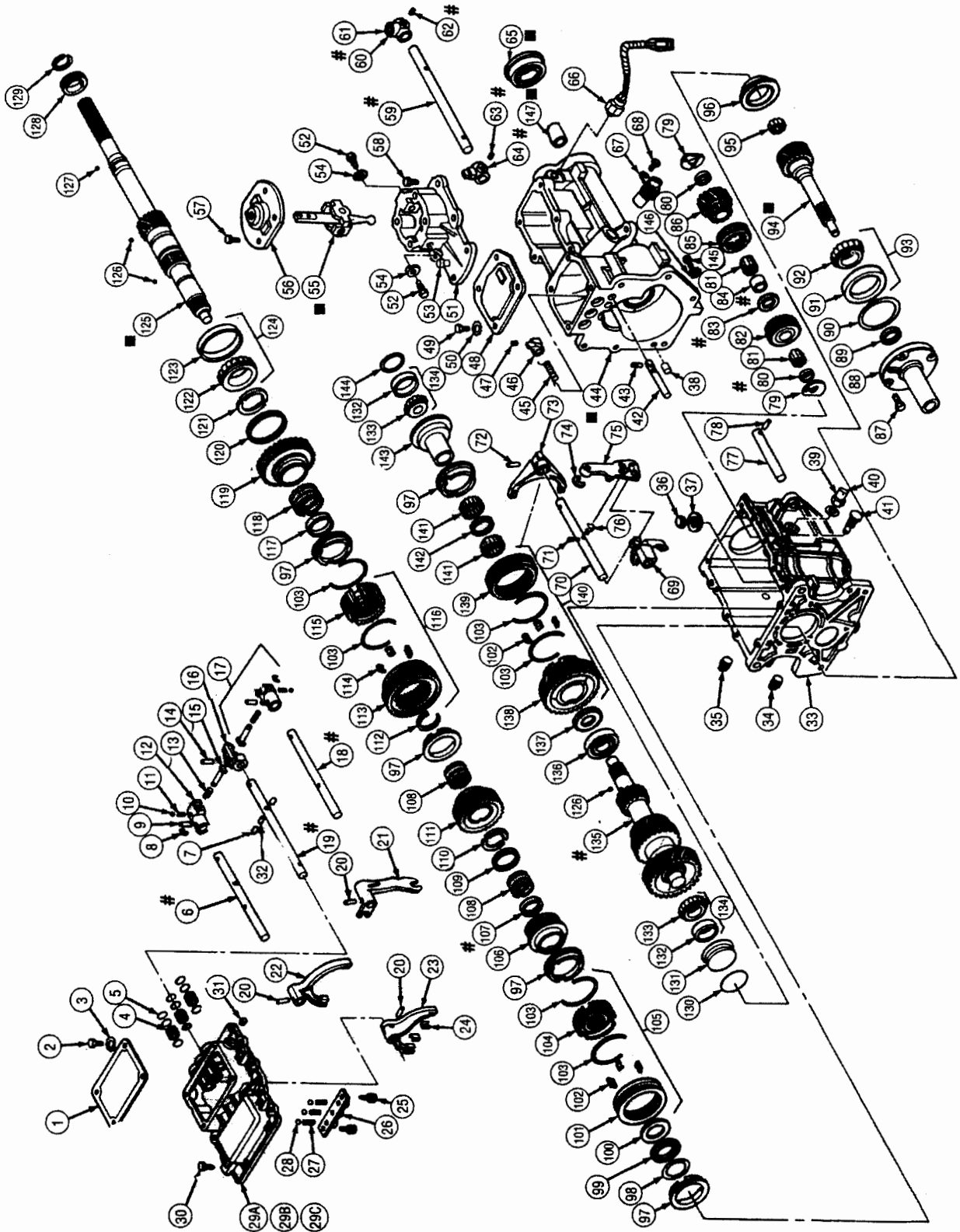

## DISASSEMBLED VIEW LEGEND

NO.	PART NO.	DESCRIPTION	NO.	PART NO.	DESCRIPTION
1	2605866	Shift Fork Inspection Cover	44A	2606415	TKO model—Extension Housing Assy (Without bushing)
2	2604902	Bolts (4 Req'd)	45	2605832	Reverse Inhibitor Spring
3	2604899	Star Washer (4 Req'd)	46	2606259	Reverse Inhibitor
4	2605811	Shift Rail Guides (3 Req'd)	47	2603897	Reverse Inhibitor Roll Pin
5	2605812	Shift Rail Guide O-Ring (9 Req'd)	48	2606248	Lug Extension Cover
6	2605804	Early—First-Second Shift Rail	49	2604902	Bolt (4 Req'd)
6A	TCBR-0004	Late—First-Second Shift Rail	50	2604899	Star Washer (4 Req'd)
7	2604895	Shift Interlock Pin (2 Req'd)	51	2671061	Shift Turret Assy
8	2605817	E-Clip Snap Ring (2 Req'd)	52	2605984	Lateral Support Pivot (2 Req'd)
9	2604154	Shift Lug Roll Pin (2 Req'd)	53	2124715	Breather
10	10J000008	Ball Bearing	54	2605949	Lateral Support Pivot Locking Tab Washer (2 Req'd)
11	2606264	Transversal Spring	55	2606237	3550 model—Shift Lever Assy (Standard Throw)
12	2606212	First-Second/Fifth-Reverse Shift Lug (2 Req'd)	55A	2670945	3550 model—Shift Lever Assy (Short Throw)
13	2606263	Piston Spring (2 Req'd)	56	2606240	Turret Dust Cover
14	14J1822	Shift Lug Roll Pin	57	2604025	Turret Dust Cover Retaining Bolt (4 Req'd)
15	2605815	Piston (2 Req'd)	58	2603968	Turret Assy Retaining Bolt
16	2606293	Third and Fourth Shift Lug	59	2606247	Early—Shift Link
17	2606265	First-Second/Fifth-Reverse Shift Lug Assy	59A	2606464	Late—Shift Link
18	2605806	Early—Fifth-Reverse Shift Rail	60	2606247	Early—Shift Lever Socket
18A	TCBR-0003	Late—Fifth-Reverse Shift Rail	60A	2606463	Late—Shift Lever Socket
19	2605805	Early—Third-Fourth Shift Rail	61	2606246	Shift Lever Socket Bushing
19A	TCBR-0002	Late—Fifth-Reverse Shift Rail	62	2601227	Early—Shift Lever Socket Assy Allen Screw
20	2604154	Shift Fork Roll Pin (3 Req'd)	62A	14J1822	Late—Shift Lever Socket Assy Allen Screw
21	2606214	Fifth-Reverse Shift Lever	63	2601227	Early—Shift Select Finger Allen Screw
22	2605808	First-Second Shift Fork	63A	14J1822	Late—Shift Select Finger Allen Screw
23	2605996	Third-Fourth Shift Fork	64	2605855	Shift Select Finger
24	2605992	Shift Fork Nylon Inserts	65	2603979	3550 Model—Extension Housing Oil Seal
25	2605829	Interlock Bracket Bolt (2 Req'd)	65A	2606416	TKO Model—Extension Housing Oil Seal
26	2605810	Interlock Spring Bracket	66	2606244	Neutral Safety Switch
27	2601082	Interlock Spring (3 Req'd)	67	17271	Speedometer Driven Gear
28	10J000012	Ball Bearing (3 Req'd)	68	99796-0616	Speedometer Cable Retaining Screw
29A	2605803	Case Cover w/o Guide Pins	69	2606216	Reverse Shift Fork Assy
29B	2605802	Case Cover w/ Guide Pins	70	2605823	Fifth and Reverse Shift Rail
29C	TCBR-0001	Late—Case Cover/Shifting Assembly	71	2604342	Reverse and Overdrive Actuating Pin Roll Pin
30	25603968	Case Cover Bolt (10 Req'd)	72	2604154	Fifth Gear Shift Fork Roll Pin
31	2605083	Interlock Plug Allen Screw	73	2606111	Fifth Gear Shift Fork Assy
32	2604832	Center Interlock Pin	74	2603965	Wave Type "E" Clip
33	2606106	Transmission Case Assy (also includes #36 & #37)	75	2605948	Reverse and Overdrive Lever
34	13F000008	Drain Plug	76	2605824	Reverse and Overdrive Actuating Pin
35	13F000008	Filler Plug	77	2605793	Reverse Shaft
36	2603939	Magnet Retainer Lock (not serviced separately)	78	14J2524	Reverse Shaft Locking Pin
37	2602631	Case Magnet (Not Serviced Separately)	79	2603695	Reverse Idler Assy Thrust Washer (2 Req'd)
38	2604636	Extension Housing-To-Case Alignment Dowel Pin			
39	2605032	Backup Lamp Switch Gasket			
40	2606249	Backup Lamp Switch			
41	2604720	Reverse Balancing Pivot Pin			
42	2606095	Reverse Inhibitor Shaft			
43	6501095	Reverse Inhibitor Shaft Allen Screw			
44	2606223	3550 model—Extension Housing Assy			
44A	2606414	TKO model—Extension Housing Assy (Includes bushing)			

## DISASSEMBLED VIEW LEGEND (CONTINUED)

NO.	PART NO.	DESCRIPTION	NO.	PART NO.	DESCRIPTION
80	2605799	Early—Roller Bearing End Spacer (2 Req'd)	116	2670739	First-Second Synchronizer Assy and Reverse Gear
80A	2606465	Late—Roller Bearing End Spacer (3 Req'd)	117	2606110	Early—Spacer (First Gear)
81	2605797	Early—Reverse Gear Roller Bearing (44 Req'd)	117A	2602650	Late—Snap Ring (First Gear Bearing)
81	2605797	Late—Reverse Gear Roller Bearing (22 Req'd)	118	2606109	Roller Bearing Assy
81A	2602661	Late—Reverse Gear Roller Bearing (44 Req'd)	119	2606070	First Gear
82	2606094	Reverse Gear	120	2605708	Split Ring Thrust Washer Retainer
83	2605795	Thrust Washer	121	2605707	Split Ring Thrust Washer
84	2605798	Early—Roller Bearing Spacer	122	2605706	Output Shaft-To-Case Bearing
84A	2606466	Late—Roller Bearing Spacer	123	2605701	Bearing Race
85	2605800	Reverse Selector Sleeve	124	2605700	Output Shaft-To-Case Bearing Assy
86	2606093	Reverse Idle Gear	125	2606242	3550 Model—Output Shaft (28 Splines)
87	2603698	Front Bearing Retainer Bolts (4 Req'd)	125A	2606413	TKO Model—Output Shaft (31 Splines)
88	2606243	Front Bearing Retainer	126	10J00006	Ball Bearing
89	2603865	Input Shaft Seal	127	10J000008	Ball Bearing
90	2606066-069	Input Shaft-To-Case Bearing Selective Shim	128	2601215	Speedometer Drive Gear
91	2605686	Input Shaft-To-Case Bearing Cup	129	2604502	Snap Ring
92	2606065	Input Shaft-To-Case Taper Roller Bearing	130	2606258	O-Ring Seal
93	2606064	Input Shaft-To-Case Taper Roller Bearing Assy	131	2606288	Case Plug
94	2606241	3550 Model—Input Shaft (10 Splines)	132	2605787	Countershaft Bearing Race (2 Req'd)
94A	2606412	TKO Model—Input Shaft (26 Splines)	133	2605788	Countershaft Bearing (2 Req'd)
95	2601210	Input Shaft Pocket Bearings (17 Req'd)	134	2605786	Countershaft Bearing Assy
96	2605768	Fourth Gear Clutch Cone	135	2606261	Early—Countershaft (One Piece)
97	2605124	Synchronizer Blocker Ring	135A	2606225	Late—Countershaft With Integral First and Second Gears
98	2705766	Thrust Washer	135B	2606232	Late—Countershaft - Fourth Gear
99	235382	Thrust Bearing	135C	2606233	Late—Countershaft - Third Gear
100	2905767	Thrust Washer	135D	5J001008	Late—Countershaft - Woodruff Keys (2 Req'd)
101	2605764	Synchronizer Collar	135E	2602645	Late—Countershaft - Snap Ring
102	2604372	Synchronizer Insert (3 Req'd)	136	2606087	Countershaft-To-Case Bearing Assy
103	2605117	Synchronizer Spring (2 Req'd)	137	2606118	Thrust Washer
104	2606083	Synchronizer Hub	138	2606089	Synchronizer Hub-Fifth Gear
105	2606082	Third-Fourth Synchronizer Assy	139	2605780	Synchronizer Collar
106	2606262	Third Gear Assy	140	2606088	Fifth Gear Synchronizer Assy
107	2606081	Early—Spacer (Third Gear)	141	2602661	Roller Bearings (86 Req'd)
107A	2606339	Late—Snap Ring (Third Gear Bearing Cage)	142	2606092	Roller Bearing Spacer
108	2606075	Roller Bearing Assy	143	2606091	Fifth Gear Clutch Cone
109	2606077	Split Ring Thrust Washer Retainer	144	2605789-792	Countershaft Rear Bearing
110	2606076	Split Ring Thrust Washer	145	1C000728	Extension Housing-To-Case Bolt (6 Req'd)
111	2606074	Second Gear	146	5E000007	Star Washer (6 Req'd)
112	2602650	Snap Ring	147	2603891	3550 Model—Extension Housing Bushing
113	2606073	Synchronizer Collar	147A	2606417	TKO Model—Extension Housing Bushing
114	2602648	Synchronizer Inserts (3 Req'd)			
115	2606072	Synchronizer Hub			

## TO REPLACE T-5 TRANSMISSION WITH TREMEC TR-3550 OR TKO HIGH PERFORMANCE TRANSMISSIONS

### Parts Required:

- Three quarts GM Synchronesh transmission fluid (GM part no. 12345349) or optional automatic transmission fluid (Dextron II®).
- Four 7/16 - 14 x 1 1/2 grade 8 bolts and lock washers (Ford part no. 57661-S2).
- Bell housing (Ford part no. D9ZC-6392-C)
- Crossmember (Ford part no. E6ZZ-6A023-A)

### Procedure Outline:

1. Remove T-5 transmission as outlined in transmission removal procedure.
2. Remove existing bell housing and clutch linkage.
3. Install new bell housing and align to crankshaft.
4. Reinstall clutch linkage.
5. Break crossmember bushing-to-crossmember tack weld with hand grinder and reposition crossmember to its most rearward position.
6. Install TREMEC TR-3550 transmission as outlined in Installation procedure using new bolts and lock washers.
7. Tack weld (in two places) the crossmember bushings to the crossmember before lowering the vehicle.

### TRANSMISSION REMOVAL

1. Remove shift knob.
2. Remove shift boot by unsnapping plastic plate which retains the shift boot.
3. Remove two bolts securing the shift handle to the shift tower.
4. Raise the vehicle on a hoist.

5. Remove oil drain plug and drain transmission. Properly dispose of oil.
6. Remove four nuts retaining exhaust pipes to exhaust manifold. Remove four nuts retaining exhaust pipes to mufflers. Remove exhaust system pipes by sliding out of retainer bracket.
7. Mark the driveshaft U-joints at the rear companion flange (yoke) so that it may be installed in the same position. Disconnect the driveshaft from the rear U-joint flange. Slide the driveshaft off the transmission output shaft.
8. Remove the two nuts retaining the rear transmission support to the crossmember. Remove bolts.
9. Support the engine and transmission with a transmission jack and raise slightly.
10. Remove the two nuts from the crossmember bolts. Remove bolts and remove crossmember.
11. Disconnect the wiring harness from the backup lamp switch. On 5.0L engines, disconnect neutral sensing switch.
12. Remove the bolt from the speedometer cable retainer and remove speedometer driven gear from the transmission.
13. Remove the four bolts retaining transmission to the flywheel housing.
 

**CAUTION: Care should be taken to ensure that lowering the transmission will not cause damage to engine components.**
14. Lower the engine enough to obtain clearance for transmission removal. Move the transmission and jack rearward until the transmission input shaft clears the fly-wheel housing.
 

**CAUTION: Do not depress the clutch pedal while the transmission is removed.**
15. Remove existing bell housing and clutch linkage as suggested in the manufacturer's service manual.



## TRANSMISSION INSTALLATION

**CAUTION:** Bell housing should be aligned to have a runout of no more than .005 inch to the crankshaft. Damage to the transmission may occur if improperly aligned.

1. Install bell housing and clutch linkage.
2. Make sure that the mounting surfaces of the transmission and flywheel housing are free of dirt, paint and burrs. Raise the transmission and move forward on the guide pins until the input shaft splines enter the clutch hub splines and the case is positioned against the fly-wheel housing. Guide pins can be installed in the two lower mounting bolt holes to ease installation.
3. Install two new 7/16 inch — 14 x 1 1/2 grade 8 bolts snug, and remove the guide pins. Install the two lower retaining bolts. Tighten all retaining bolts to 61-89.4 N•m (45-66 lb-ft).
4. Connect the speedometer cable to the extension housing. Install the speedometer driven gear and secure. Tighten the retaining screw 4-6 N•m (3-5 lb-ft).
5. Using a transmission jack, raise the rear of the transmission and install the transmission support. Install and tighten retaining bolts to 48.8-67.7 N•m (36-50 lb-ft).
6. With the crossmember firmly held on the workbench, break the bushing-to-crossmember tack welds with a hand grinder. NOTE: The bushing must slide freely in the crossmember.
7. Position crossmember in the side brackets and install crossmember bolts. Install the two nuts and tighten to 34-48 N•m (25-35 lb-ft).
8. With the transmission extension housing resting on the engine rear support, slide the crossmember to its most rearward position and install the transmission extension housing retaining bolts. Tighten the bolts to 34-48 N•m (25-35 lb-ft).
9. Tack weld, in two places, the crossmember bushing to the crossmember.
10. Connect the backup lamp switch wiring harness. On 5.0L engines, connect neutral sensing switch to the wiring harness.
11. Reinstall exhaust system pipes and torque nuts to 27-41 N•m (20-30 lb-ft).
12. Slide the forward end of the driveshaft over the transmission output shaft. Ensure driveshaft index marks align. Connect the driveshaft to the rear U-joint flange. Tighten U-bolt nuts to 56.9-77.2 N•m (42-57 lb-ft).
13. Fill the transmission to the proper level with approximately three quarts of GM Synchronesh transmission fluid (GM part no. 12345349).
14. Lower vehicle.
15. Install shifting handle to shifting tower by installing and tightening the two retaining bolts and tighten to 29.8-43.3 N•m (22-32 lb-ft). Snap plastic plate into console.
16. Reinstall shift knob.
17. Check the shift and crossover motion for full shift engagement and smooth crossover operation.

**DISASSEMBLY—TRANSMISSION**

1. Drain transmission fluid.
2. Remove transmission from vehicle as outlined.
3. Properly mount transmission in bench-mounted holding fixture.

**NOTE:** Perform Steps 4 through 13 only if the shift lever is loose. If the shift lever is not loose, go to Step 14.

4. Remove four shift turret dust cover bolts.

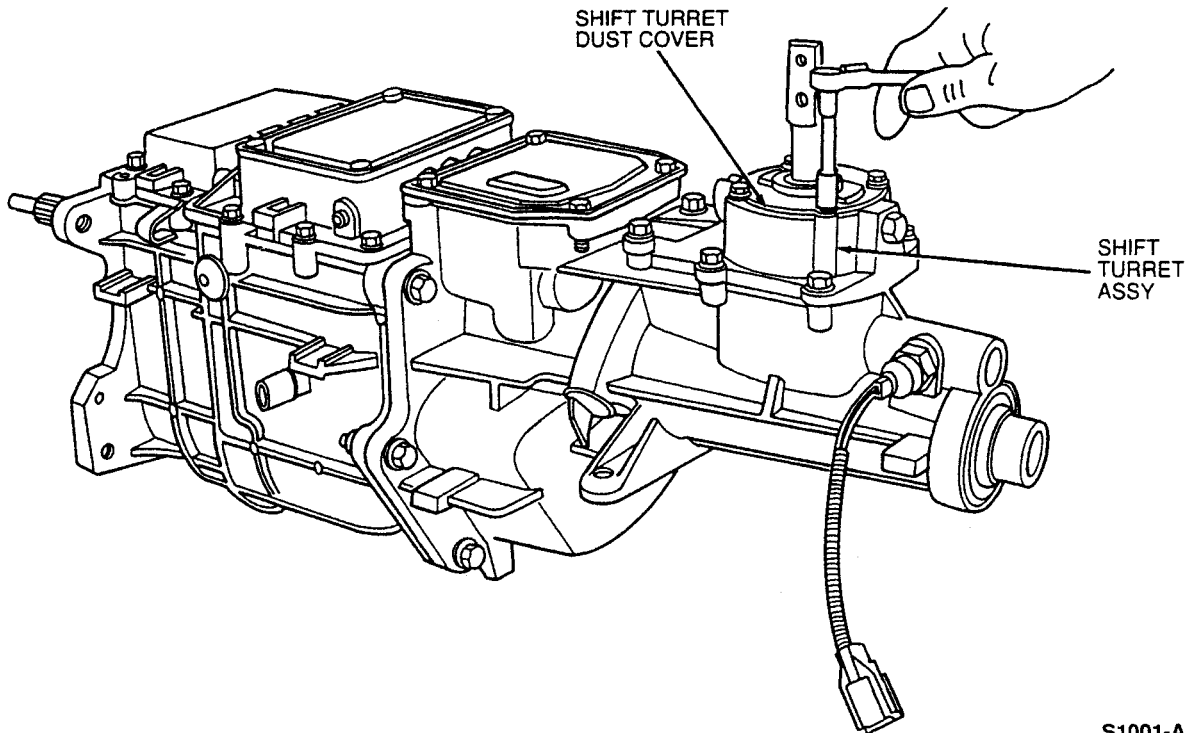

S1001-A

5. Remove dust cover.
  6. Inspect shift lever for looseness.
- NOTE:** Shifter should be loose without excessive movement. Excessive lateral movement or end play may indicate worn or damaged components.
7. Straighten locking tabs holding shift lever pivot bolts.
  8. Remove two shift lever pivot bolts.

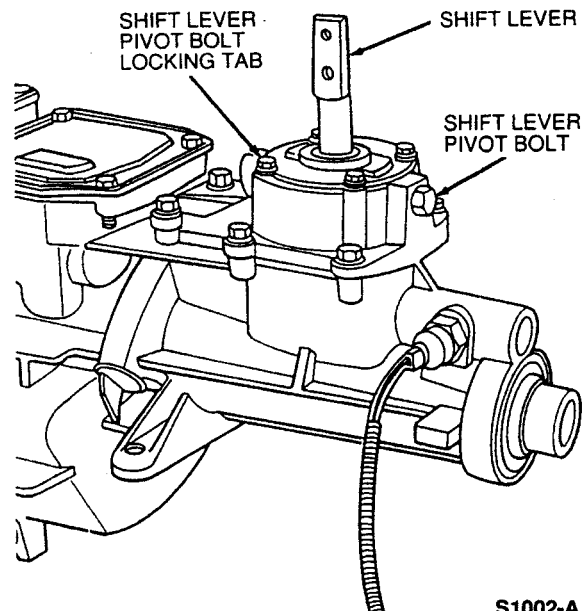

S1002-A

DISASSEMBLY—TRANSMISSION (CONTINUED)

9. Remove shift lever assembly.

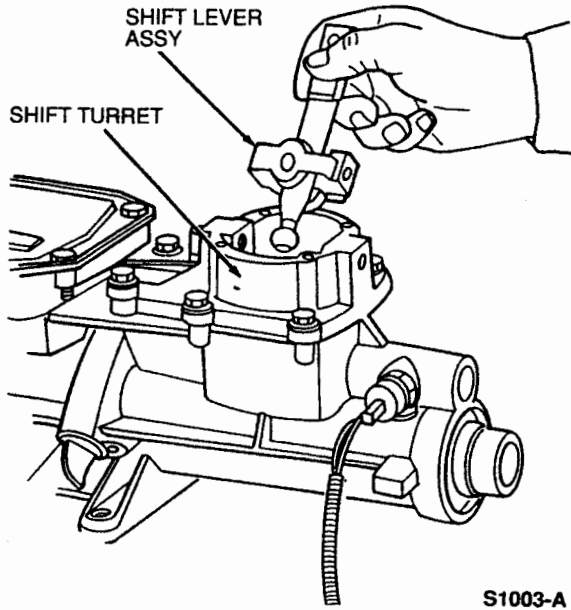

10. Inspect ball on end of shift lever for wear (excessive).
11. Remove six shift turret housing bolts.
12. Remove shift turret.
13. Inspect shifter ball socket bushing for wear. Replace if worn.

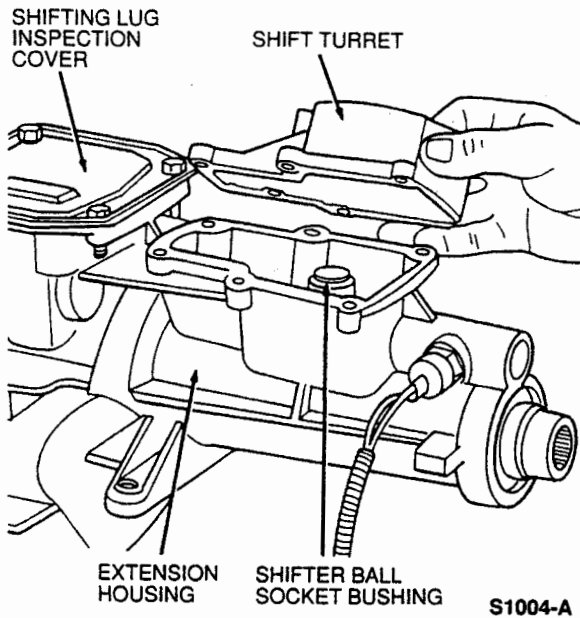

14. Remove four shifting lug inspection cover bolts and star washers.
15. Remove shifting lug inspection cover.

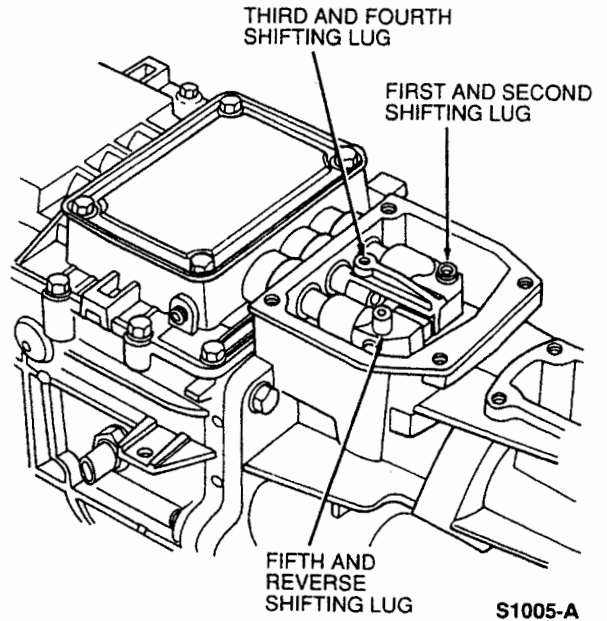

NOTE: Insert a magnet into area under shifting lugs to catch roll pins when pushed free.

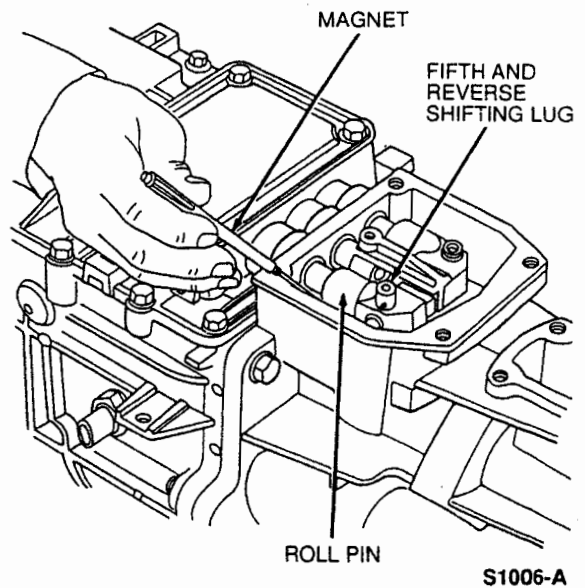

**DISASSEMBLY — TRANSMISSION (CONTINUED)**

16. Using a pin punch, remove roll pin securing the fifth and reverse shifting lug to the fifth and reverse shift rail.
17. Remove fifth and reverse shifting lug and roll pin.

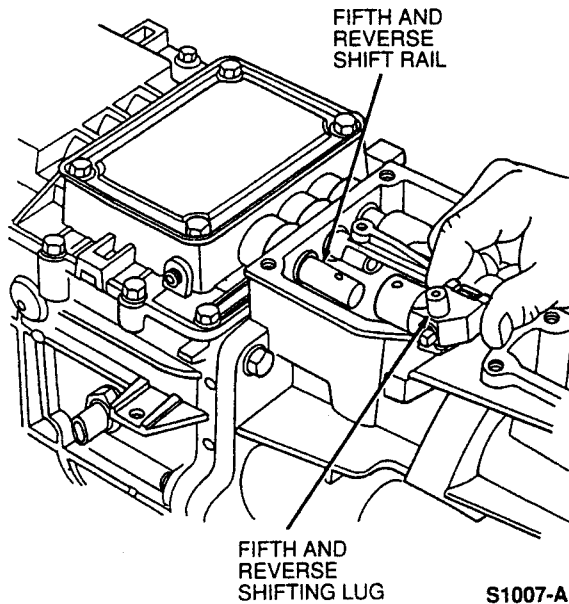

18. Using a pin punch, remove the first and second shifting lug roll pin.
19. Remove first and second shifting lug.

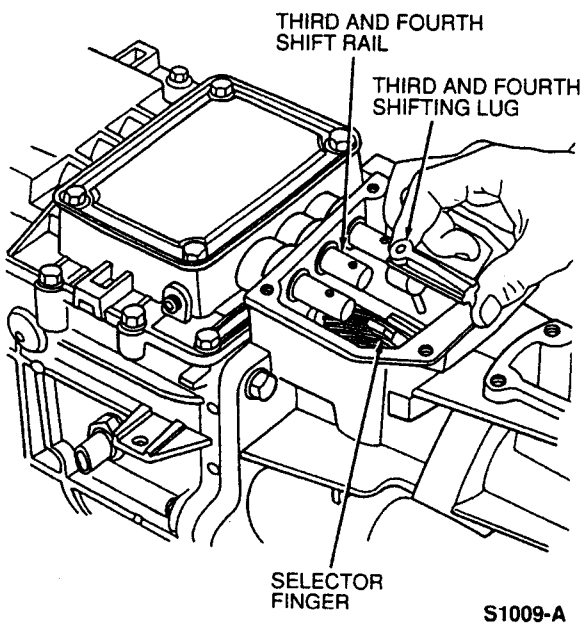

20. Rotate shifting selector rail moving selector finger away from the third and fourth shifting lug.
21. Using a pin punch, remove the third and fourth shifting lug roll pin.
22. Remove third and fourth shifting lug.

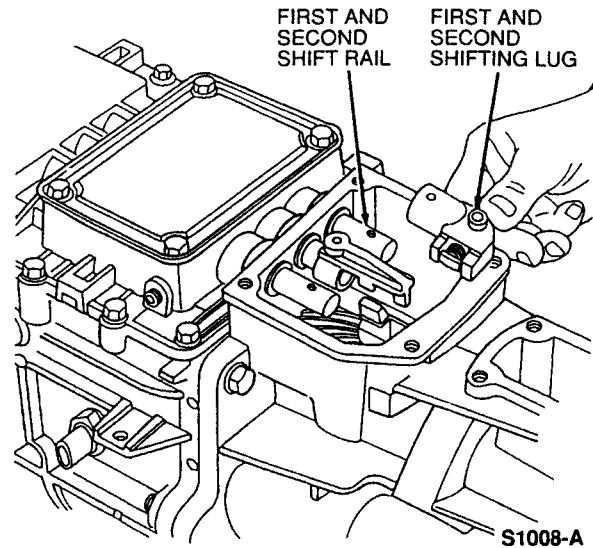

23. Remove six extension housing-to-transmission case retaining bolts.

**NOTE:** Mark placement of transmission identification tag.

24. Remove extension housing.

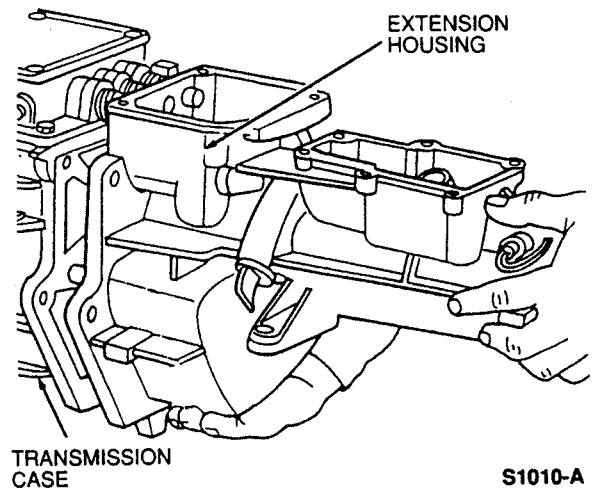

**DISASSEMBLY—TRANSMISSION (CONTINUED)**

- 25. Remove four transmission case inspection cover bolts and star washers.
- 26. Remove transmission case inspection cover.

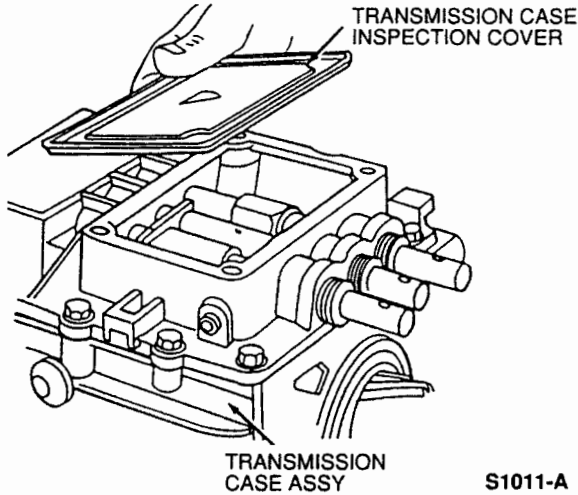

- 27. Remove 10 transmission case cover-to-case bolts.
- NOTE: Mark location of wiring harness strap.
- 28. Remove case cover and shifting mechanism.

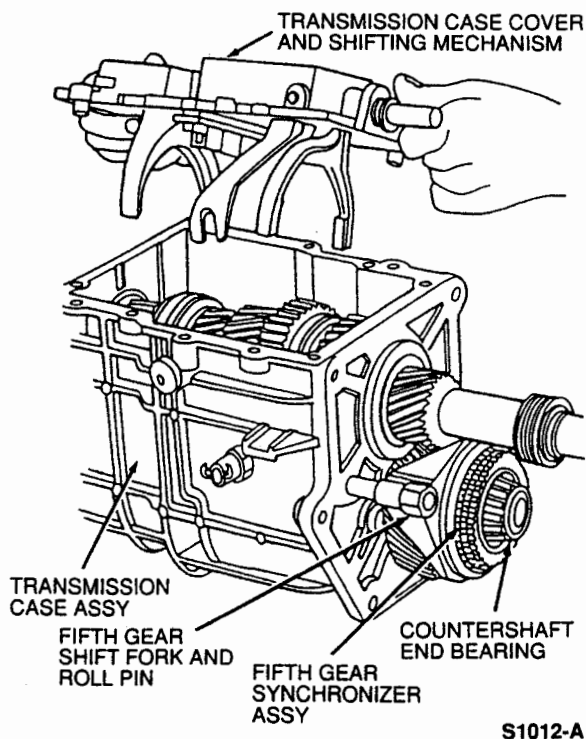

- 29. Using pin punch, remove fifth gear shifting fork roll pin.
- 30. Remove fifth gear synchronizer assembly and shift fork together.

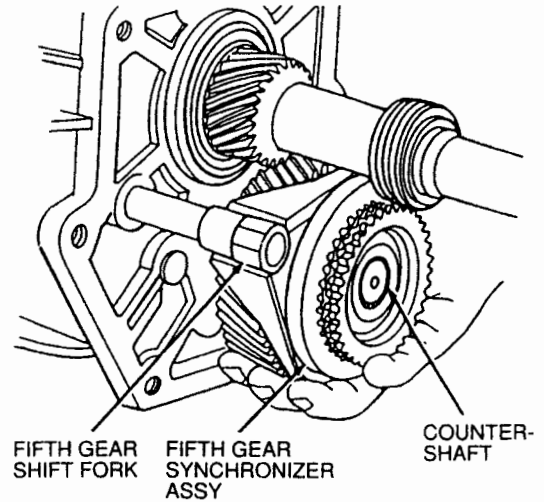

NOTE: Be careful to remove the fifth gear synchronizer thrust washer with the fifth gear synchronizer assembly to prevent possible loss of the roller bearings located inside the fifth gear synchronizer assembly.

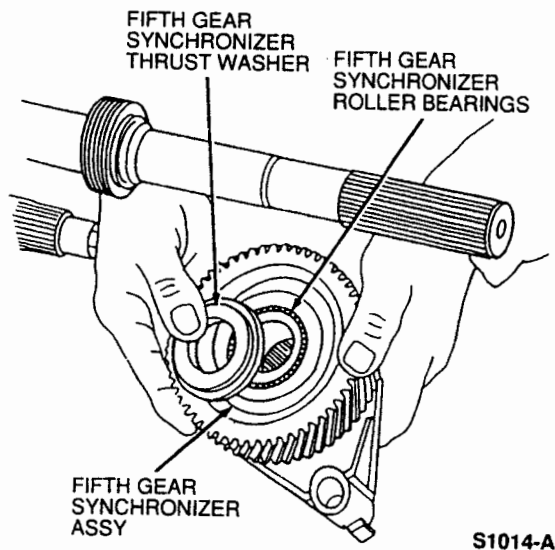

NOTE: Be careful not to lose the thrust washer locking-and-bearing retaining ball when fifth gear synchronizer assembly is removed. Remove ball from countershaft with a magnet.

**DISASSEMBLY — TRANSMISSION (CONTINUED)**

31. Using universal dial indicator, measure first, second and third gear end play. (0.000-0.016 inch, maximum of 0.018 inch). Record for reference.

Gear rattle or clunking noise indicates possible excessive backlash.

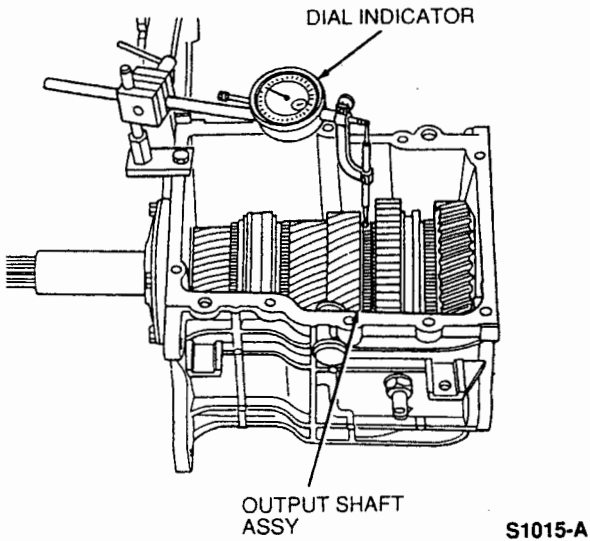

32. Using universal dial indicator, measure gear backlash on first, second and third gears (0.000 - 0.016 inch). Record for reference.

NOTE: Insert a screwdriver between countershaft drive gear on transmission case to prevent movement of the countershaft assembly.

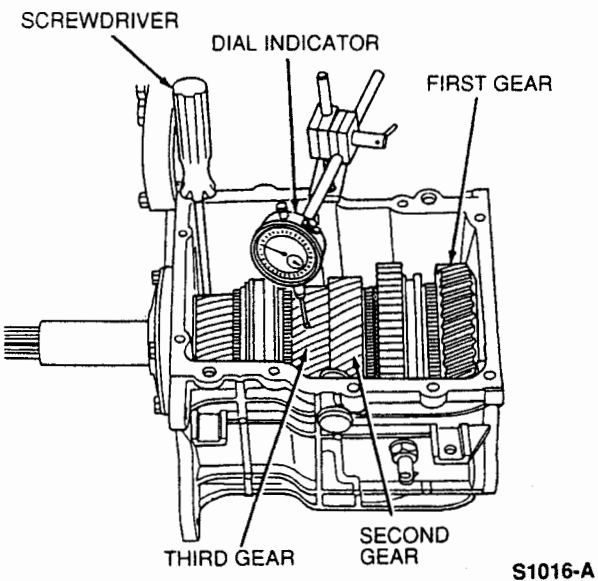

33. Remove four front bearing retaining bolts.

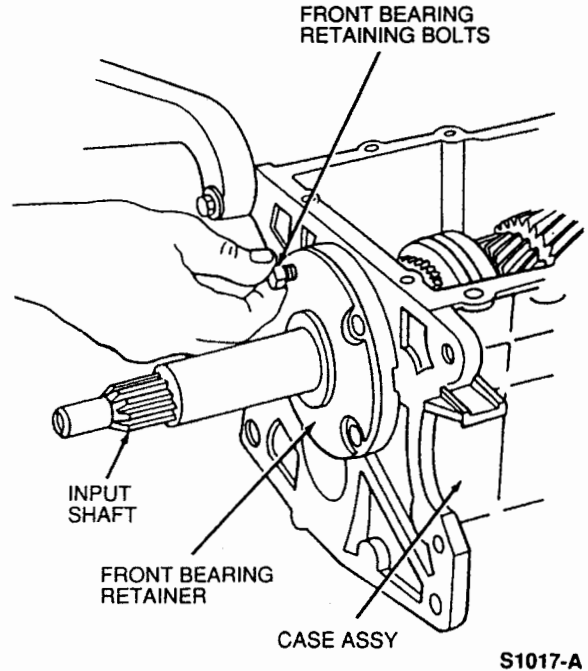

34. Remove front bearing retainer.

NOTE: Be careful not to lose the front bearing shims that are positioned in the bearing retainer.

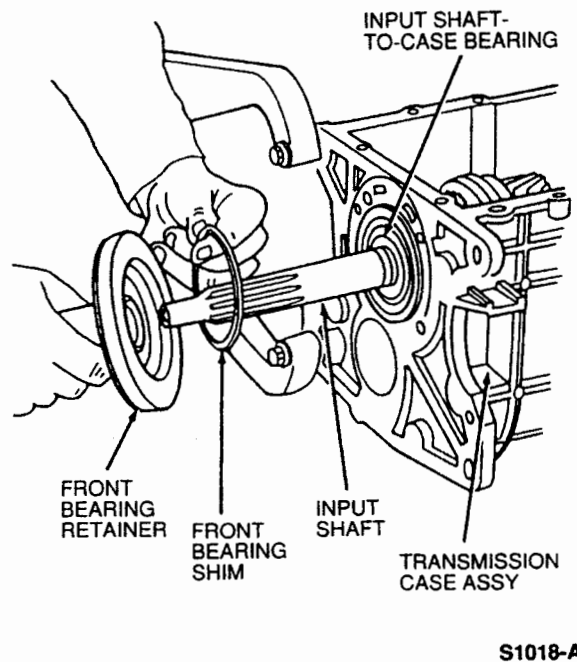

**DISASSEMBLY — TRANSMISSION (CONTINUED)**

35. Remove input shaft and bearing assembly.

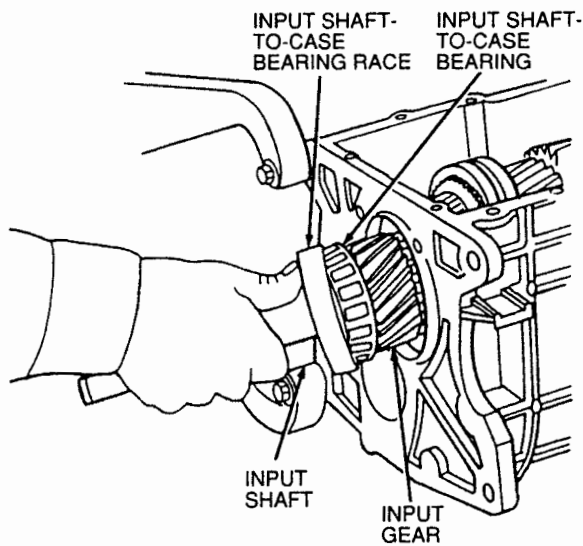

S1019-A

NOTE: Be careful not to lose the 17 roller bearings inside the shaft assembly between the input shaft and output shaft.

36. Remove output shaft-to-case bearing race.  
37. Remove output shaft assembly.

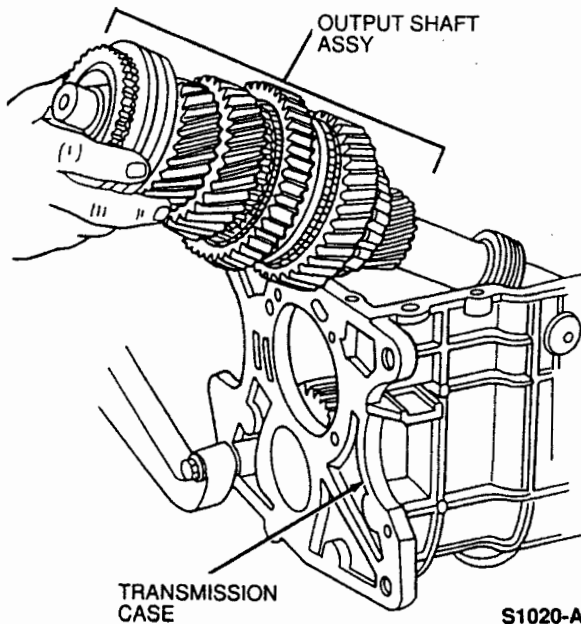

S1020-A

38. Using a pin punch, remove roll pin retaining the selector link pin to the fifth and reverse shift rail.

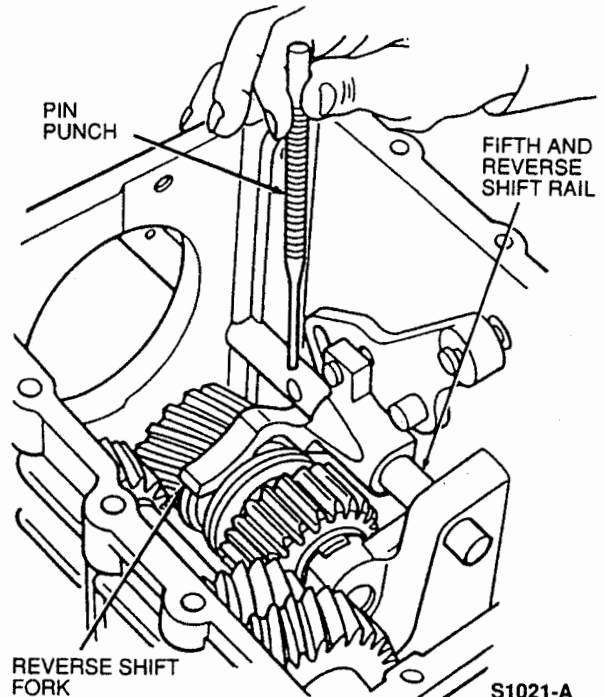

S1021-A

39. Rotate fifth and reverse shift rail counterclockwise disengaging selector link pin from selector link.  
40. Remove selector link pin from fifth and reverse shift rail.

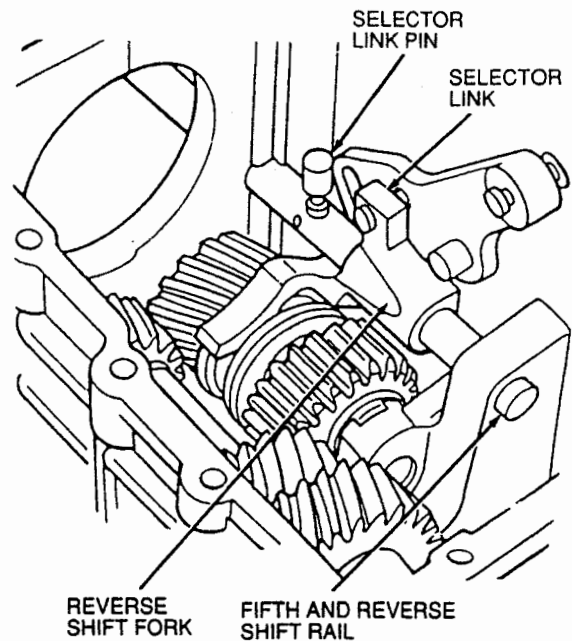

S1022-A

**DISASSEMBLY — TRANSMISSION (CONTINUED)**

41. Remove fifth and reverse shifting rail.

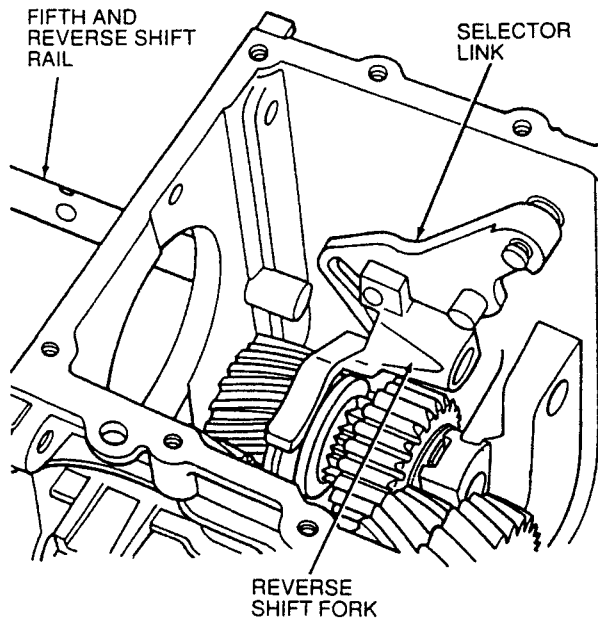

S1023-A

43. Remove selector link retaining clip (E-clip) and selector link.

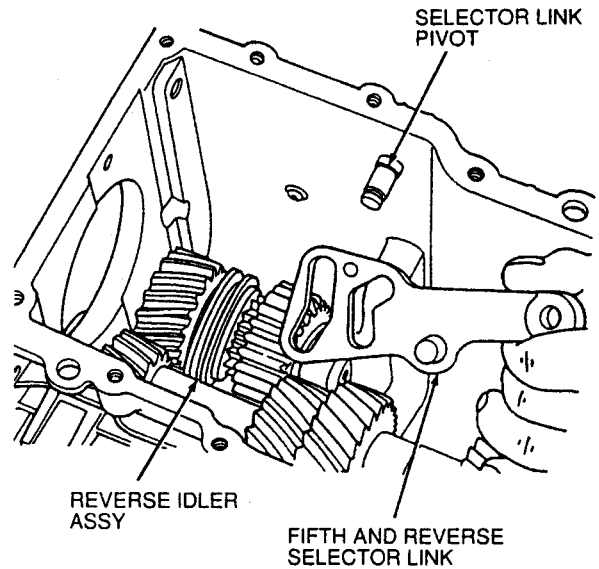

S1025-A

42. Remove reverse shift fork.

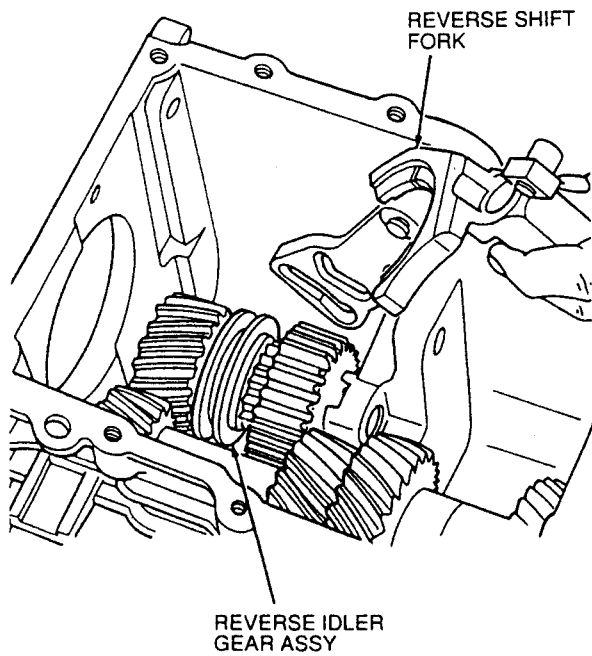

S1024-A

44. Remove reverse idler gearshaft.

NOTE: Do not remove roll pin from shaft unless shaft is to be replaced.

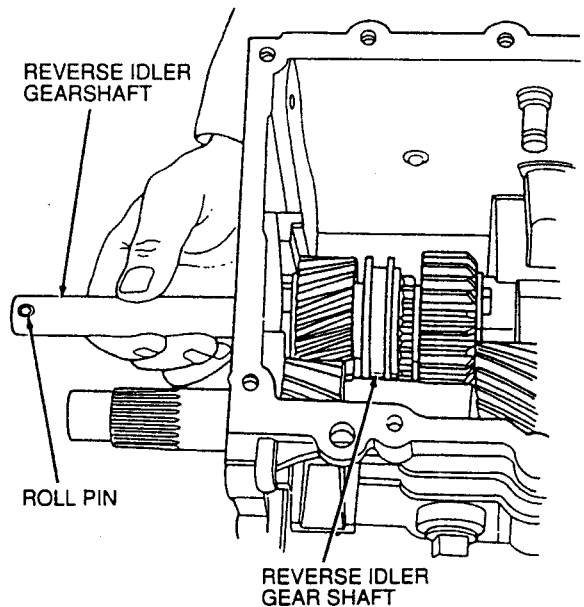

S1026-A



**DISASSEMBLY — TRANSMISSION (CONTINUED)**

- 45. Remove reverse idler gear assembly as a complete assembly.

NOTE: Be careful not to lose the 44 needle bearings.

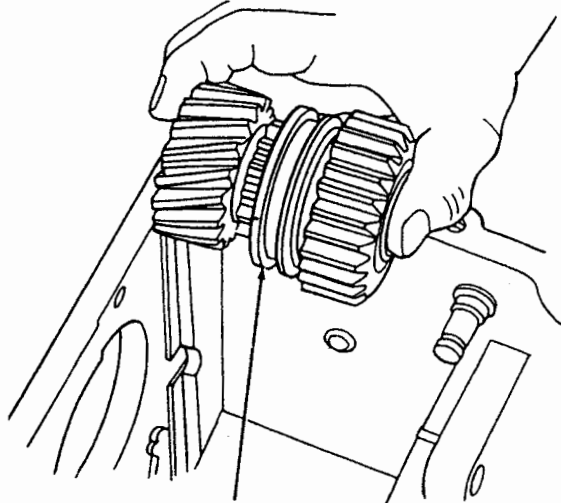

REVERSE IDLER GEAR ASSY

S1027-A

- 46. Slide reverse idler gearshaft through assembly to maintain integrity of assembly.

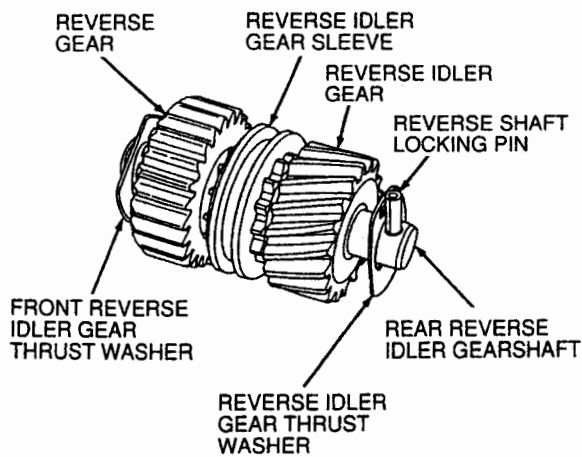

S1028-A

- 47. Remove cluster shaft intermediate roller bearing.

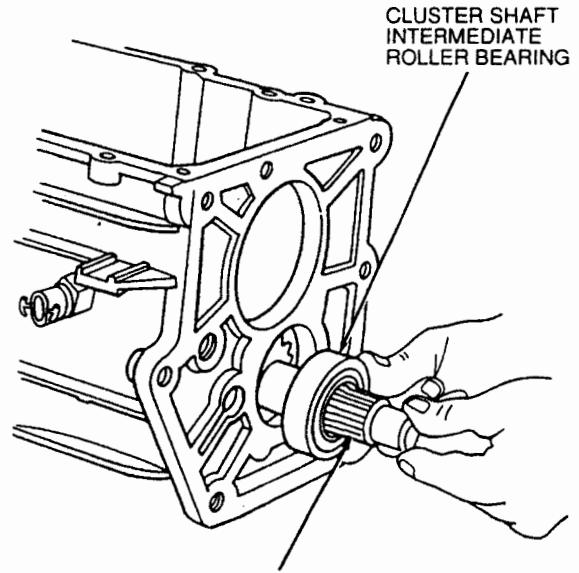

CLUSTER SHAFT INTERMEDIATE ROLLER BEARING

CLUSTER GEARSHAFT

S1029-A

- 48. Remove cluster gear assembly.

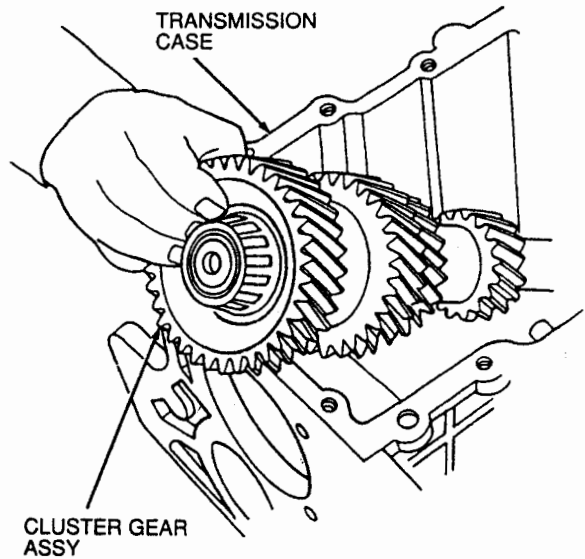

TRANSMISSION CASE

CLUSTER GEAR ASSY

S1058-A

**DISASSEMBLY AND ASSEMBLY—SUBASSEMBLIES****Input Shaft Bearing****Disassembly and Assembly**

1. Mount input shaft assembly in hydraulic press.
2. Press off input shaft front bearing.

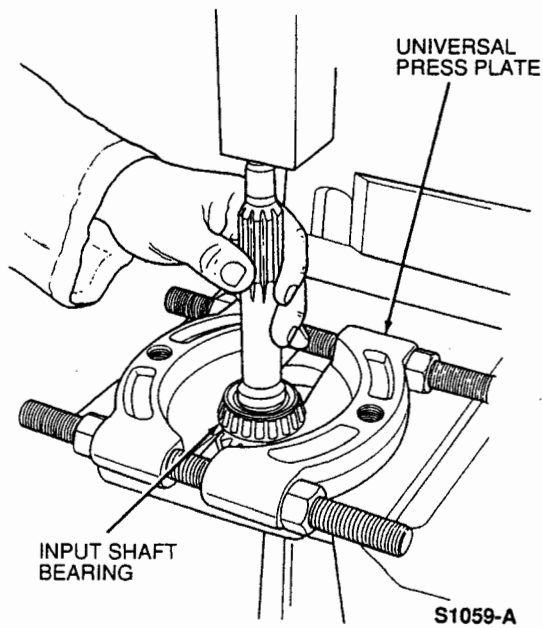

3. To assemble, mount shaft in hydraulic press.
4. Press new bearing onto input shaft.

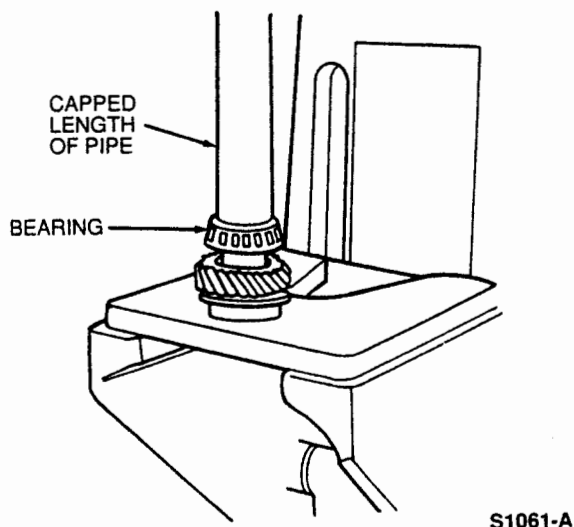
**Countershaft (Cluster Gear) —  
Early One-Piece Design****Disassembly and Assembly**

1. Mount countershaft assembly in hydraulic press with universal press plate C-clamp positioned under the tapered roller bearing.
2. Press off the countershaft tapered roller bearing.

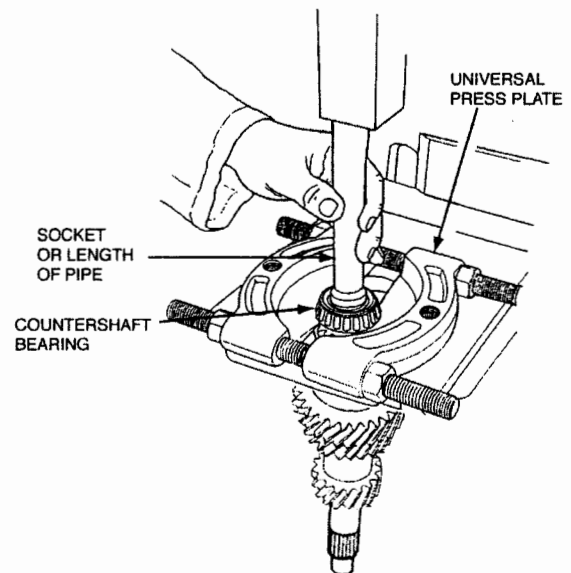

3. To assemble, mount the countershaft in hydraulic press and press on the bearing.

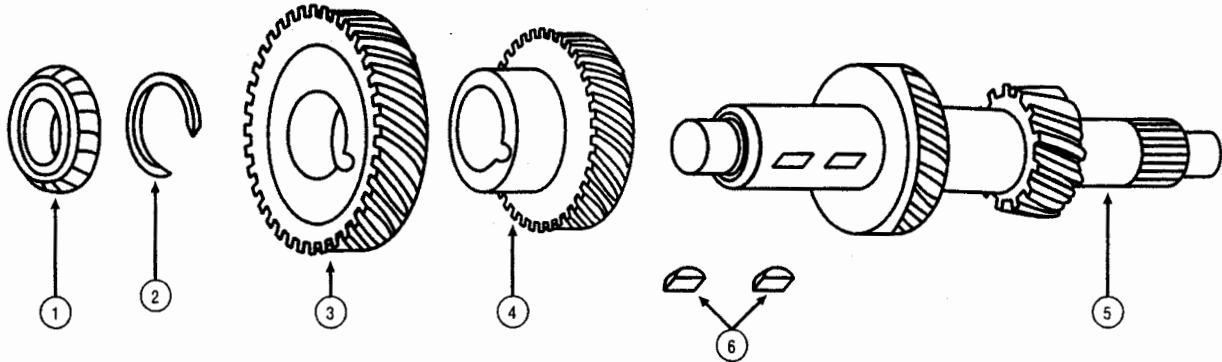
**DISASSEMBLY AND ASSEMBLY—SUBASSEMBLIES (CONTINUED)****Countershaft (Cluster Gear) —  
Late Three-Piece Design**

ITEM NO.	PART NUMBER	DESCRIPTION
1	2605786	Tapered Roller Bearing
2	2602645	Snap Ring
3	2606232	Cluster — Head (Fourth) Gear
4	2606233	Cluster — Third Gear
5	2606225	Cluster — Shaft and First/Second Gears
6	5J001008	Woodruff Key (2 Req'd)

**Disassembly**

1. Mount countershaft assembly in hydraulic press with universal press plate C-clamp positioned under the tapered roller bearing (see illustration on page 16).
2. Press off the countershaft tapered roller bearing.
3. Remove the snap ring.
4. Position universal press plate C-clamp under the head (fourth) gear. Press off head gear, and remove the Woodruff key.
5. Position universal press plate C-clamp under the third gear. Press off the third gear, and remove the Woodruff key.

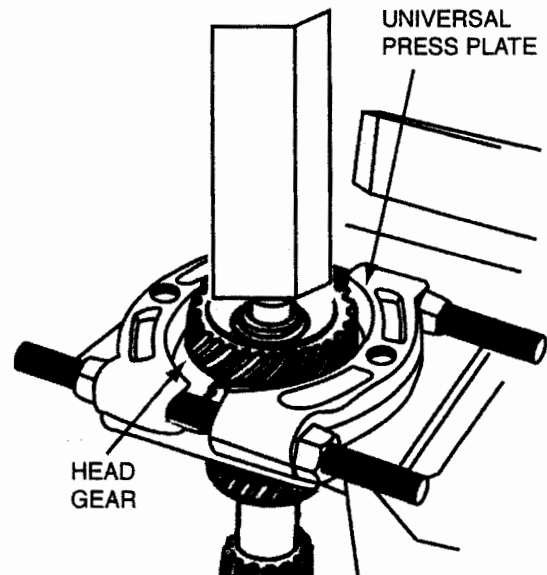

## DISASSEMBLY AND ASSEMBLY—SUBASSEMBLIES (CONTINUED)

## Assembly

**CAUTION:** The slot in the head gear and the third gear, and the matching Woodruff keys on the countershaft must be accurately aligned (see illustration) prior to pressing on the gears to avoid damage during installation.

1. Mount countershaft in a hydraulic press with universal press plate C-clamp positioned under the second gear.
2. Install the third gear Woodruff key in the slot on the countershaft, with the top of the Woodruff key parallel to the countershaft.

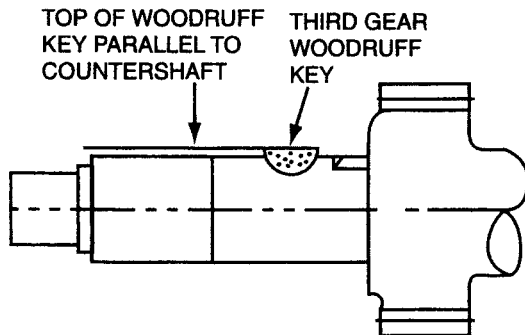

3. Accurately align the slot in the third gear with the Woodruff key.

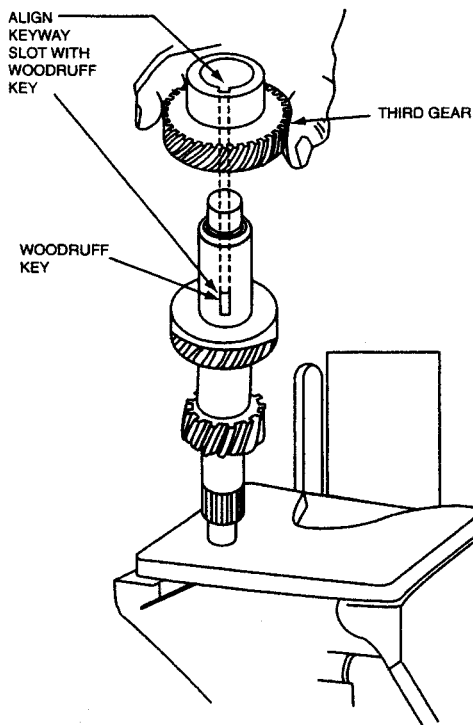

4. Carefully press on the third gear.

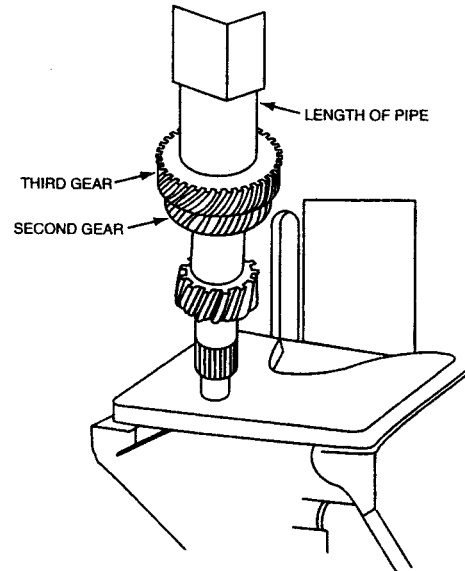

5. Install the head gear Woodruff key in the slot on the countershaft, with the top of the Woodruff key parallel to the countershaft.

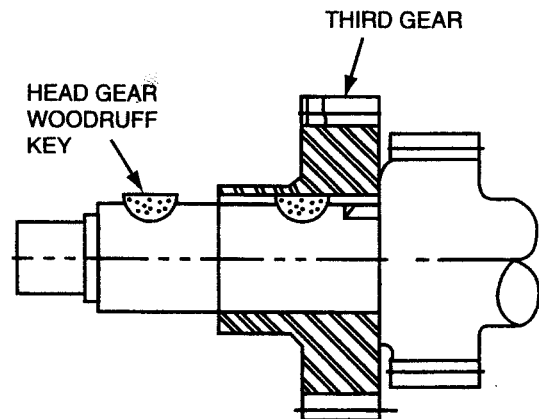

6. Accurately align the slot in the head gear with the Woodruff key.
7. Carefully press on the head gear.
8. Install the snap ring.
9. Press on the tapered roller bearing.

**DISASSEMBLY AND ASSEMBLY — SUBASSEMBLIES**

**Fifth Gear Synchronizer Assembly**

**Disassembly**

1. Remove fifth gear shift fork.
2. Remove fifth gear and synchronizer ring assembly.
3. Remove 43 roller bearings.
4. Remove roller bearing spacer.
5. Remove 43 roller bearings.
6. Remove fifth gear blocker ring.
7. Remove fifth gear clutch cone.

**Assembly**

1. Load 43 roller bearings around the fifth gear clutch cone. Use ET-M11 grease to hold bearings in place.
2. Install roller bearing spacer.
3. Load remaining 43 roller bearings around the fifth gear clutch cone. Use ET-M11 grease to hold bearings in place.
4. Slide blocker ring into position.
5. Install fifth gear and synchronizer ring assembly.
6. Install fifth gear shift fork.

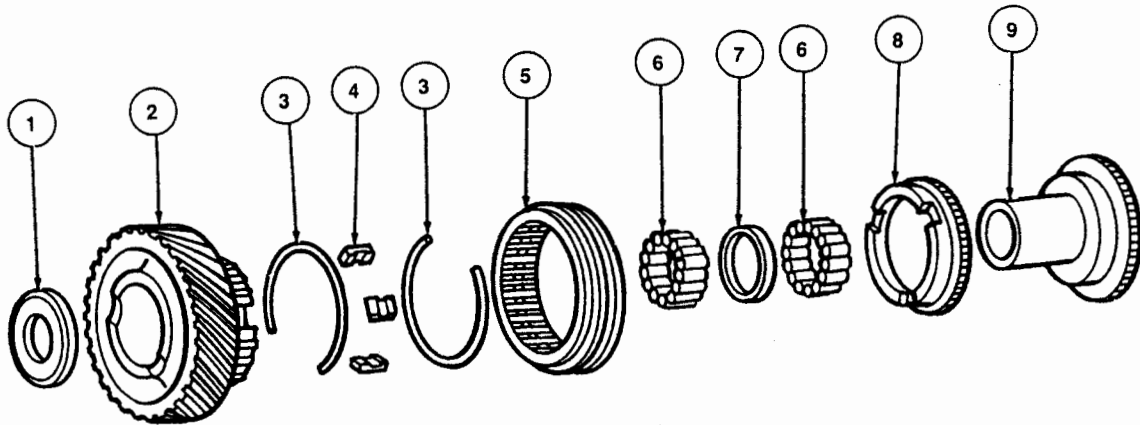

ITEM NO.	PART NO.	DESCRIPTION
1	2606118	Thrust Washer
2	2606089	Fifth Gear and Synchronizer Hub Assy
3	2605117	Synchronizer Spring (2 Req'd)
4	2604372	Synchronizer Insert (3 Req'd)
5	2605780	Synchronizer Collar
6	2602661	Roller Bearings (86 Req'd)
7	2606092	Roller Bearing Spacer
8	2605124	Synchronizer Blocker Ring
9	2606091	Fifth Gear Clutch Cone

**DISASSEMBLY AND ASSEMBLY — SUBASSEMBLIES (CONTINUED)****Reverse Idler Assembly —  
Early and Late Designs****Disassembly**

1. Remove front thrust washer.

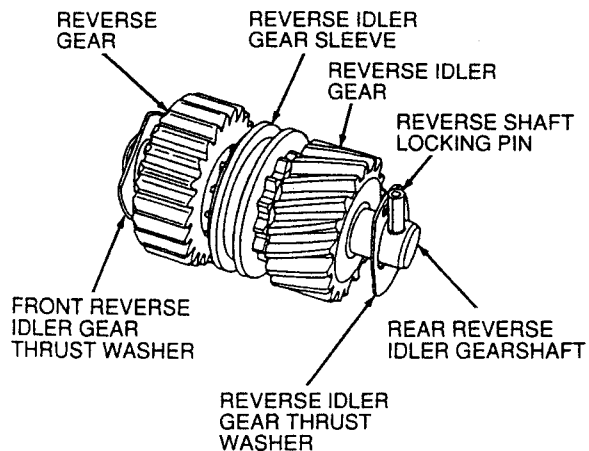

S1028-A

2. Remove bearing end spacer.

3. Remove reverse gear.

NOTE: 22 roller bearings are inside the reverse gear of early and late designs.

4. Remove center thrust washer.

5. Remove roller spacer.

6. Remove reverse sleeve.

7. Remove reverse idler gear.

NOTE:

Early Design — 22 roller bearings inside.

Late Design — 44 roller bearings inside.  
(Two rows of 22 roller bearings, separated by a spacer.)

8. Remove roller bearing end spacer.

9. Remove rear thrust washer.

**Assembly**

NOTE: During assembly, use ET-M11 grease to hold bearings in place.

1. Install roller bearing end spacer.

2. Early Design — Load 22 roller bearings into reverse idler gear.  
Late Design — Load 22 roller bearings into reverse idler gear. Install roller bearing spacer, then load a second row of 22 roller bearings (total of 44).

3. Install center roller spacer.

4. Install reverse idler gear selector sleeve.

5. Install thrust washer.

6. Install reverse idler gear.

7. Load 22 roller bearings into reverse gear.

8. Install end spacer.

9. Install thrust washer.

**DISASSEMBLY AND ASSEMBLY — SUBASSEMBLIES (CONTINUED)**

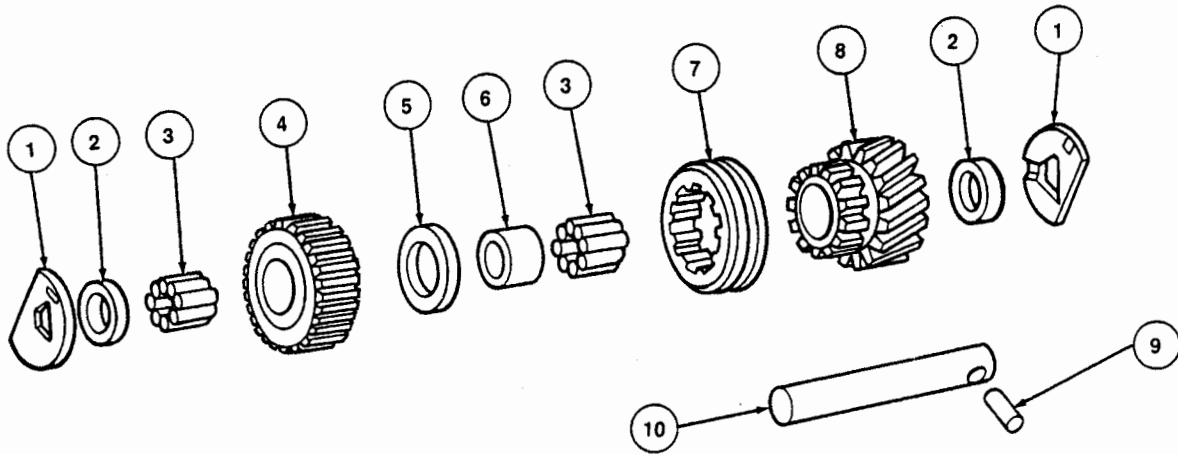

**Early Design — Reverse Idler Assembly**

S1052-A

ITEM NO.	PART NO.		DESCRIPTION
	Early Design	Late Design	
1	2603695 (2 Req'd)	2603695 (2 Req'd)	Thrust Washer
2	2605799 (2 Req'd)	N.A.	Roller Bearing End Spacer
2A	N.A.	2606465 (3 Req'd)	Roller Bearing End Spacer
3	2605797 (44 Req'd)	2605797 (22 Req'd)	Roller Bearing
3A	N.A.	2602661 (44 Req'd)	Roller Bearing
4	2606094	260694	Reverse Gear
5	2605795	2605795	Thrust Washer
6	2605798	N.A.	Roller Spacer
6A	N.A.	260466	Roller Spacer
7	2605800	2605800	Reverse Selector Sleeve
8	2606093	2606093	Reverse Idler Gear
9	14T2524	14T2524	Reverse Idler Gearshaft Locking Pin
10	2605793	2605793	Reverse Idler Gearshaft

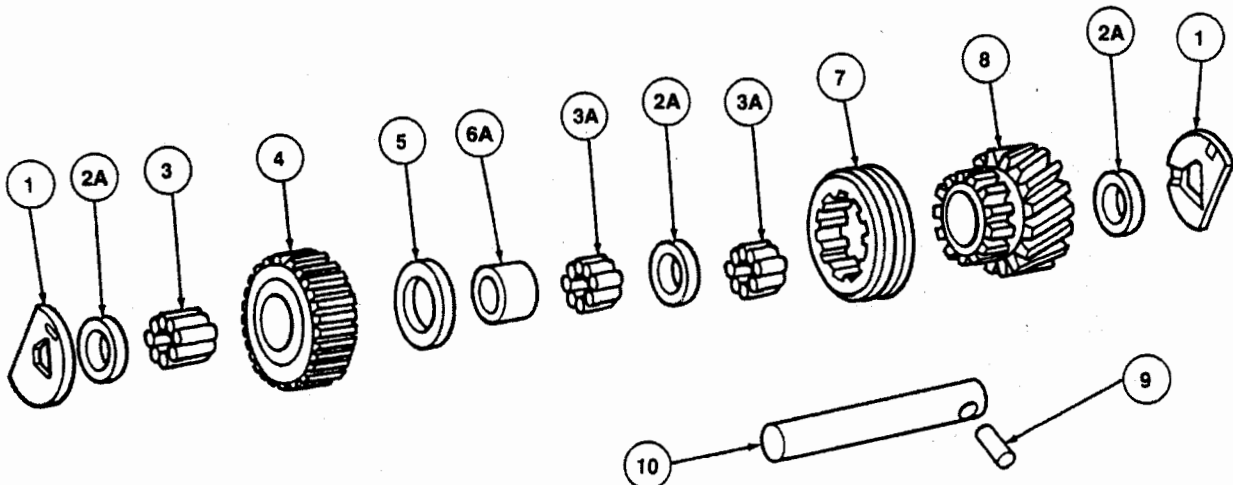

**Late Design — Reverse Idler Assembly**

**DISASSEMBLY AND ASSEMBLY — SUBASSEMBLIES (CONTINUED)****Output Shaft and Gear Assembly —  
Early and Late Designs****Disassembly and Assembly**

1. Remove input shaft thrust bearing outer race.
2. Remove input shaft thrust bearing.
3. Remove input shaft thrust bearing inner race.
4. Remove fourth gear synchronizer blocker ring and clutching cone.
5. Remove third and fourth gear synchronizer assembly.

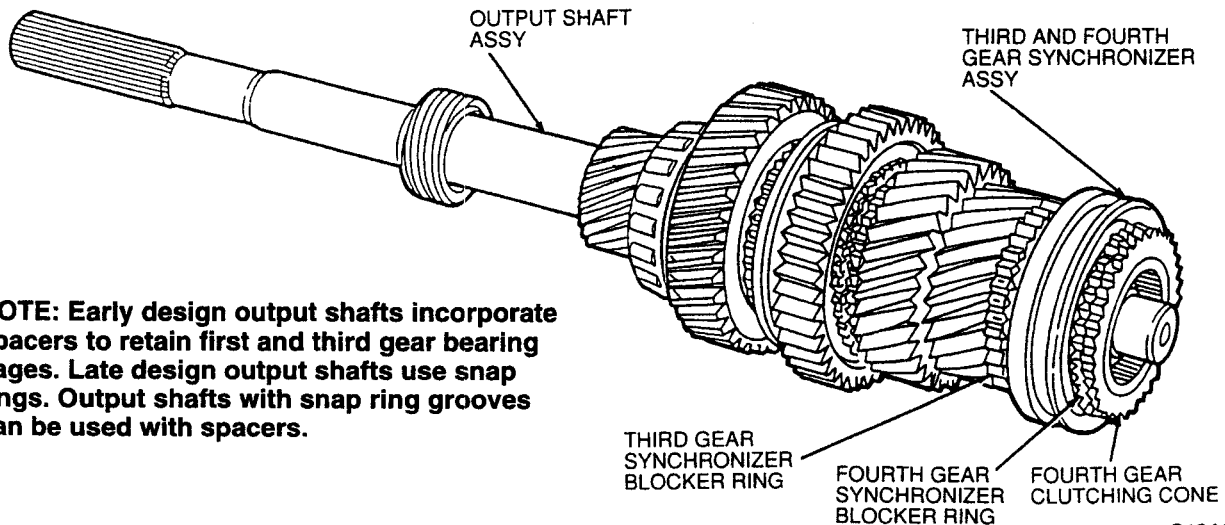

**NOTE:** Early design output shafts incorporate spacers to retain first and third gear bearing cages. Late design output shafts use snap rings. Output shafts with snap ring grooves can be used with spacers.

S1044-A

6. Remove third gear synchronizer blocker ring.
7. Early Design — Remove third gear bearing spacer.
8. Remove third gear. Late Design — Remove third gear bearing snap ring.
9. Remove third gear roller bearing.

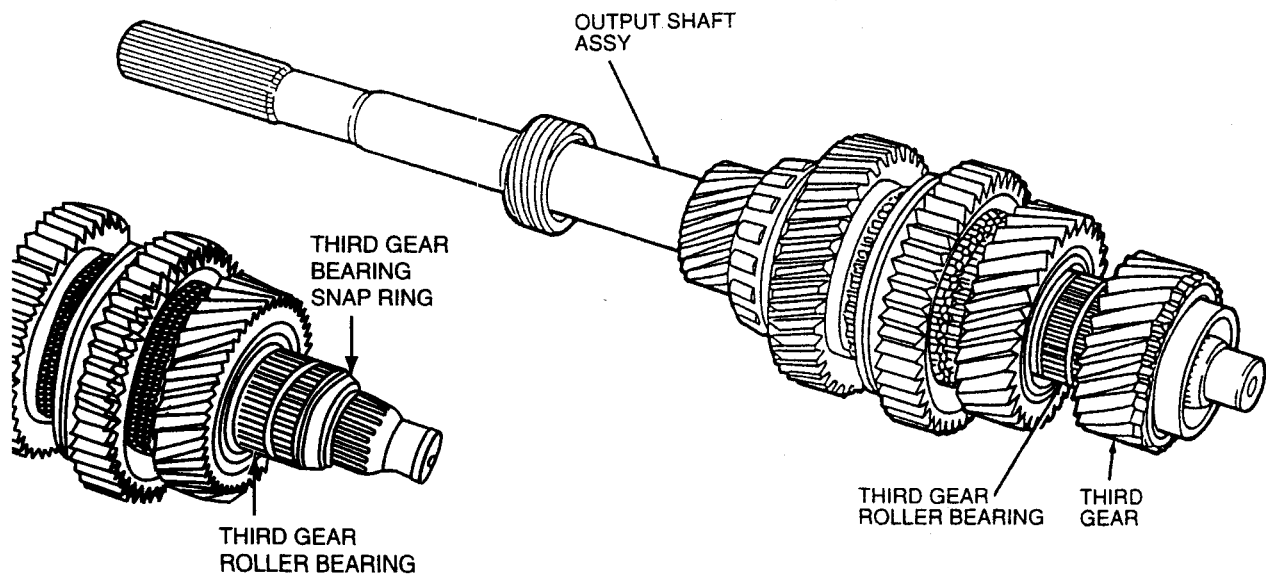
**Late Design — Output Shaft****Early Design — Output Shaft**



**DISASSEMBLY AND ASSEMBLY — SUBASSEMBLIES (CONTINUED)**

- 10. Remove split collar thrust washer retaining ring.
- 11. Remove split collar thrust washer.
- 12. Remove locking ball with a magnet.

- 13. Remove second gear.
- 14. Remove second gear roller bearing.
- 15. Remove second gear synchronizer blocker ring.

**CAUTION: Do not lose ball.**

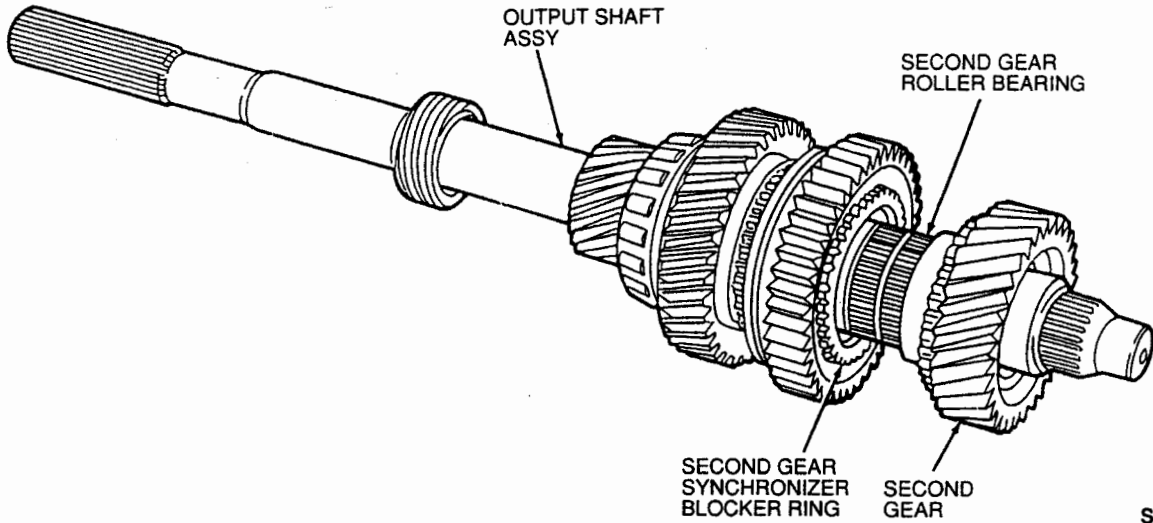

S1046-A

- 16. Remove snap ring.
- 17. Remove reverse gear and second gear and first gear synchronizer assembly.

- 18. Remove first gear synchronizer blocker ring.

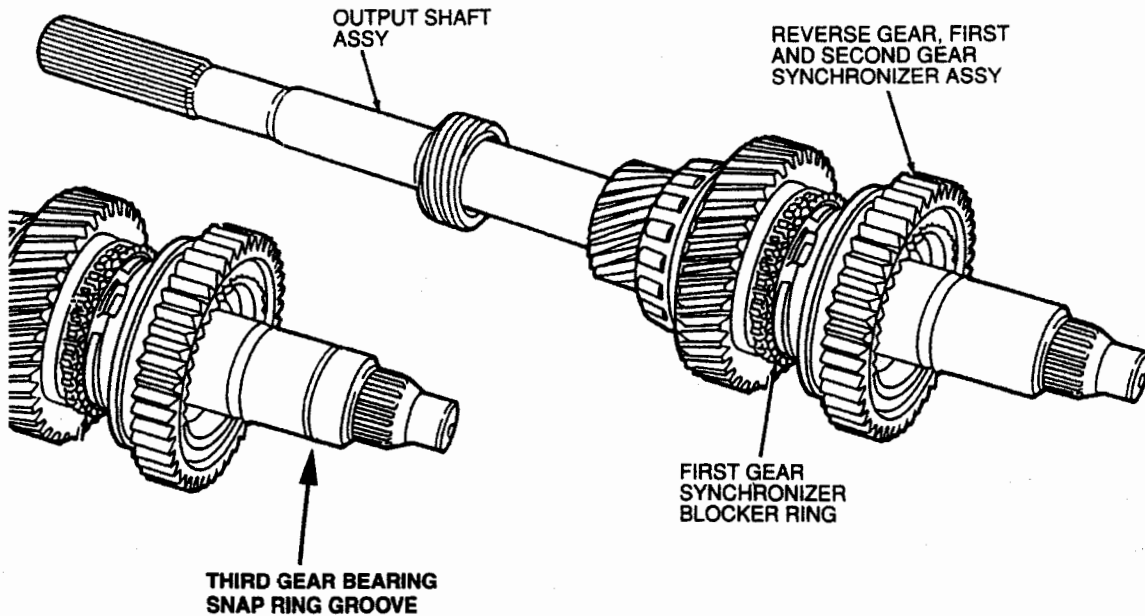

S1047-A

**Late Design — Output Shaft**

**Early Design — Output Shaft**

**DISASSEMBLY AND ASSEMBLY — SUBASSEMBLIES (CONTINUED)**

19. Remove first gear.

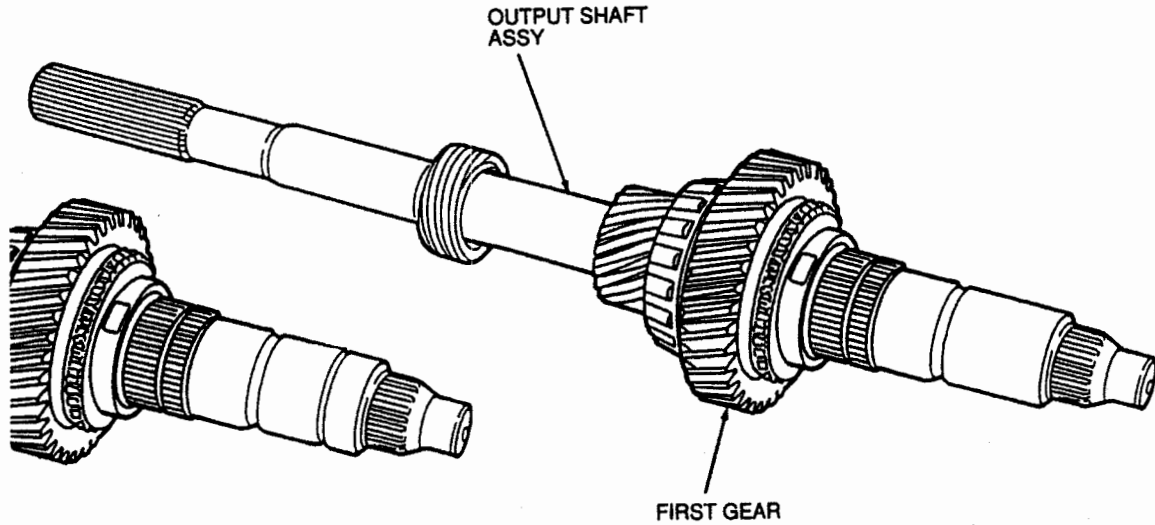

**Late Design — Output Shaft**

**Early Design — Output Shaft**

S1048-A

20. Early Design — Remove first gear bearing spacer.

Late Design — Remove first gear bearing snap ring.

21. Remove first gear roller bearing.

22. Remove split collar thrust washer retaining ring.

23. Remove split collar thrust washer.

24. Remove locking ball with a magnet.

**CAUTION: Do not lose ball.**

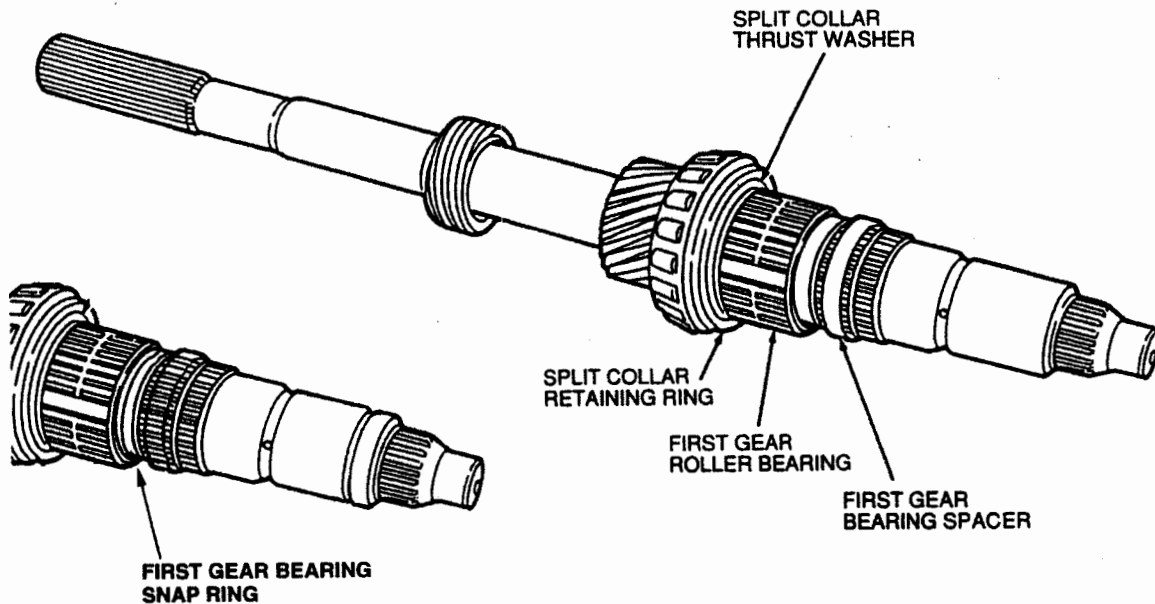

**Late Design — Output Shaft**

**Early Design — Output Shaft**

S1049-A

**DISASSEMBLY AND ASSEMBLY — SUBASSEMBLIES (CONTINUED)**

25. Remove output shaft rear bearing.

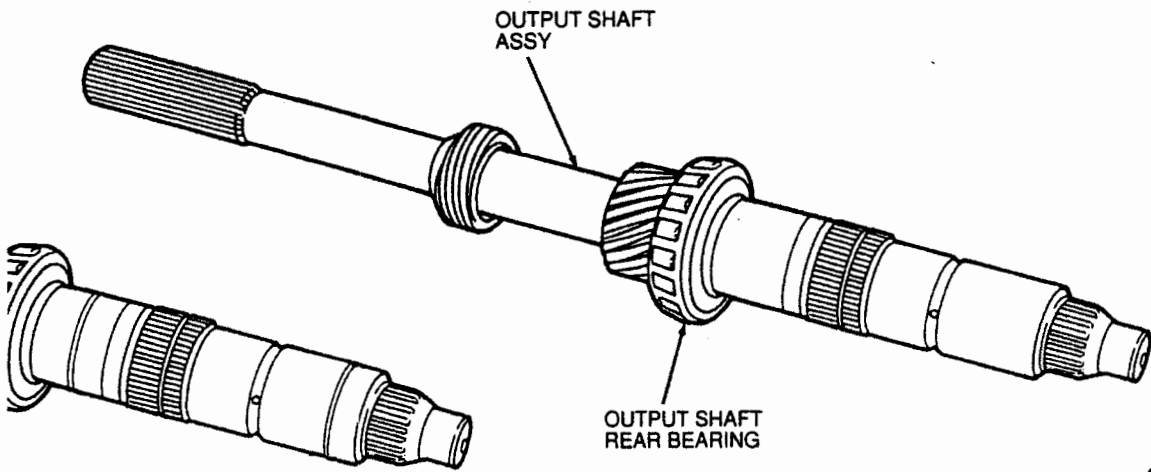

S1050-A

**Late Design — Output Shaft**

**Early Design — Output Shaft**

26. Remove speedometer gear snap ring.

27. Remove speedometer gear.

28. Remove speedometer gear locking ball bearing.

29. To assemble, reverse Disassembly procedure.

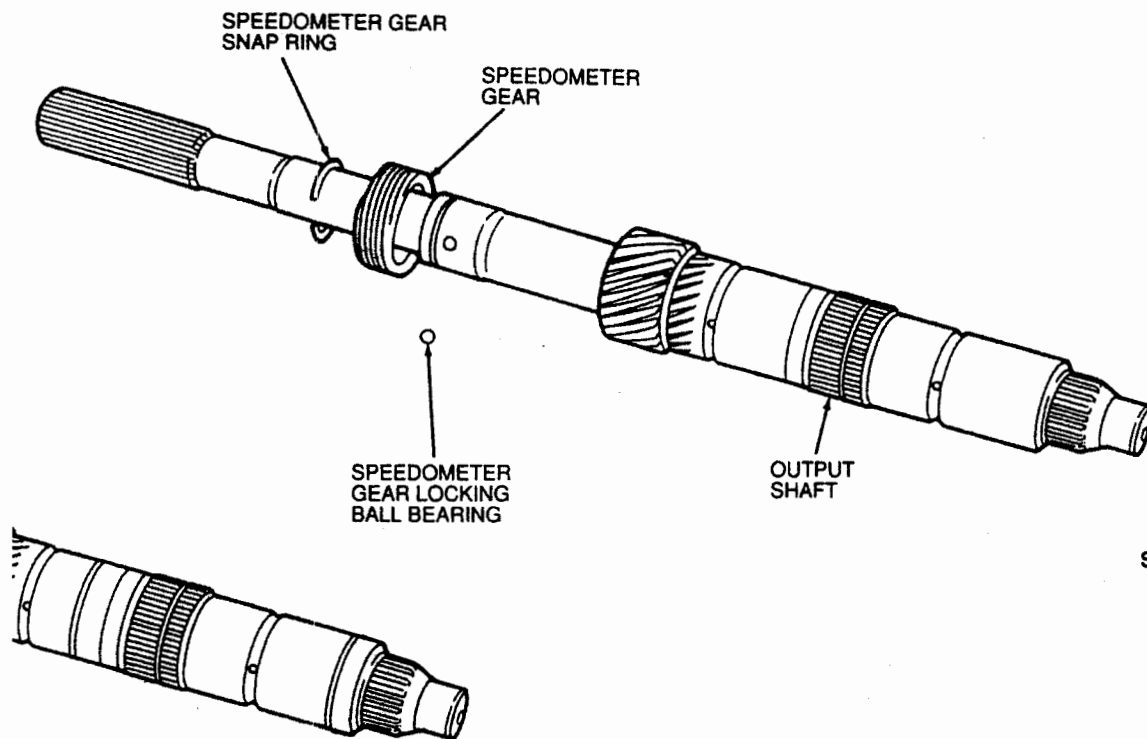

S1051-A

**Late Design — Output Shaft**

**Early Design — Output Shaft**

**DISASSEMBLY AND ASSEMBLY — SUBASSEMBLIES (CONTINUED)****Synchronizer****Disassembly**

1. Remove synchronizer insert retaining springs.
2. Slide synchronizer sleeve off synchronizer hub.
3. Remove three synchronizer inserts.

**Assembly**

NOTE: All synchronizer sleeves and hubs are marked for select fit.

1. Align select fit marks on synchronizer sleeve and hub and assemble sleeve on hub.
2. Install three inserts into synchronizer assembly.
3. Install insert retaining springs.

NOTE: Make sure that tabs on end of springs are installed in opposite directions.

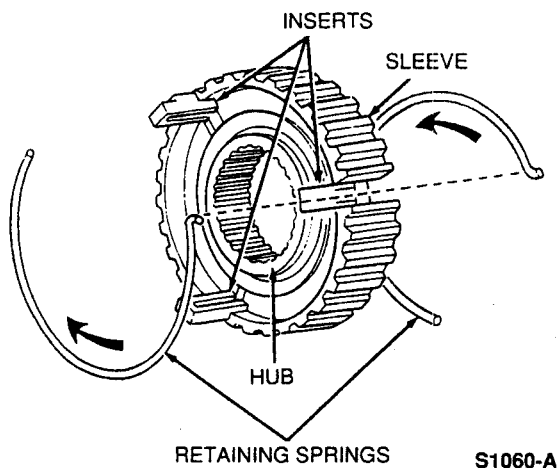
**Case Cover and Shifting Mechanism****Disassembly**

1. Remove shifting fork roll pins.

NOTE: Rotate third and fourth shifting fork to gain access to roll pin.

2. Remove spring interlock bracket bolts.

NOTE: Bracket retains tension on shift interlock springs and ball bearings.

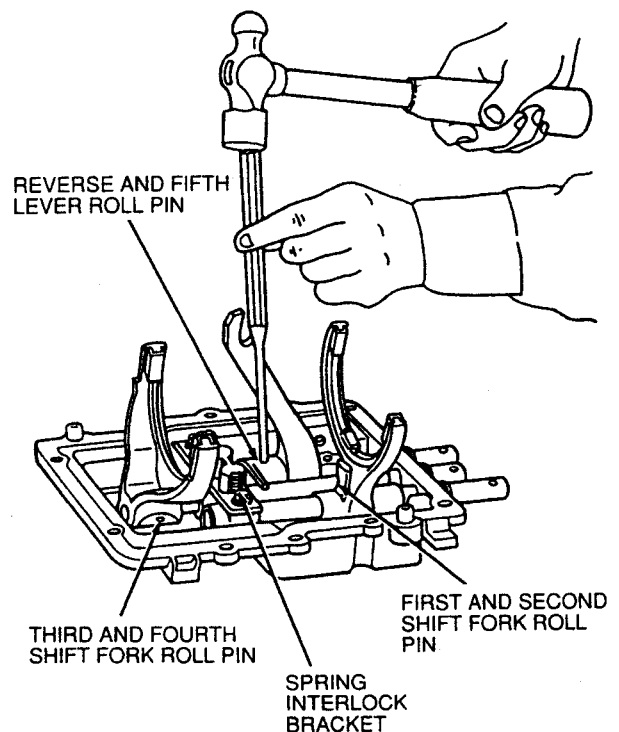

3. Remove shift interlock springs and ball from case cover.
4. Remove Allen-head screw plug from case cover.

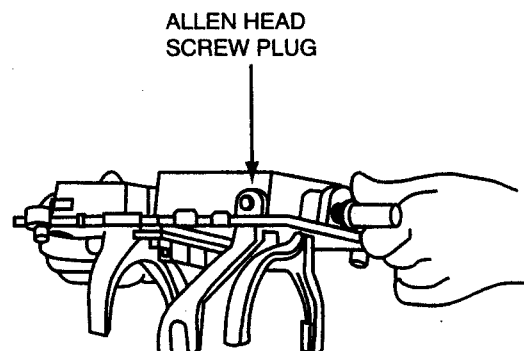

**DISASSEMBLY AND ASSEMBLY — SUBASSEMBLIES (CONTINUED)**

5. Rotate fifth and reverse shift rail 90-degrees.
6. Remove fifth and reverse shift lever while sliding fifth and reverse shift rail from transmission case cover.
7. Remove fifth and reverse shift rail by pulling out through rear end of case cover.
8. Remove three shift interlock pins from shifting rails of transmission case cover using a magnet.

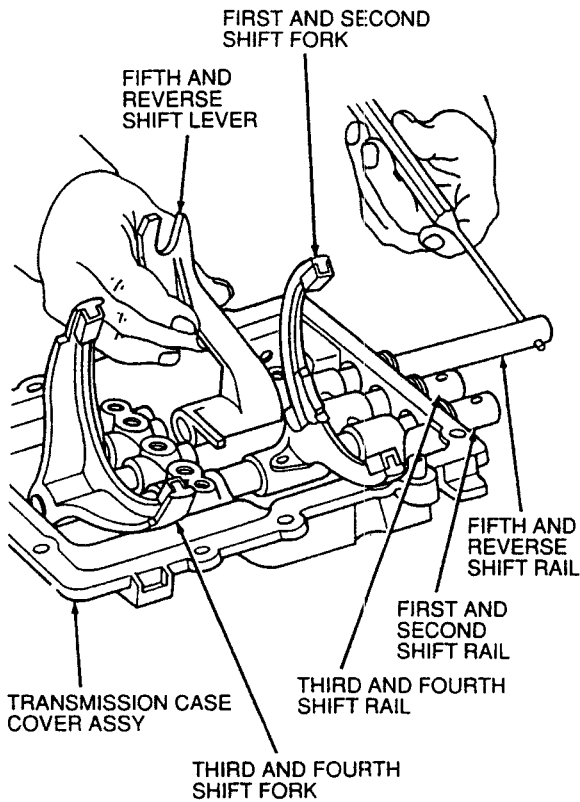

S1041-A

9. Remove third and fourth shift rail and shift fork.
10. Remove first and second shift rail and shift fork.
11. Remove three shift rail guides.

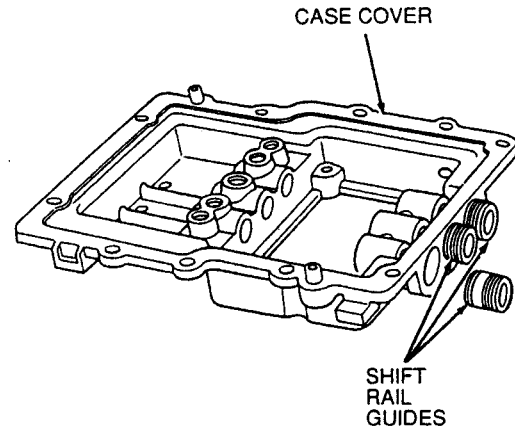

S1042-A

**Assembly**

**NOTE:** Inspect and replace O-ring seals on shift rail guides as necessary.

1. Install first and second shift rail and shift fork.
2. Install first and second shift fork roll pin.
3. Install third and fourth shift rail and shift fork.
4. Install third and fourth shift fork roll pin.
5. With cover on side, so the three shift interlock pins will be in the vertical position, install a large pin, the smaller center pin, and finally the second large pin.
6. Install fifth and reverse shift rail.
7. Install fifth and reverse shift lever and roll pin.

**DISASSEMBLY AND ASSEMBLY — SUBASSEMBLIES (CONTINUED)**

8. Install Allen-head screw plug and tighten to 14.9-21.6 N•m (11-16 lb-ft).

NOTE: Make sure fifth and reverse shift rail guides are properly positioned on third and fourth shift rail.

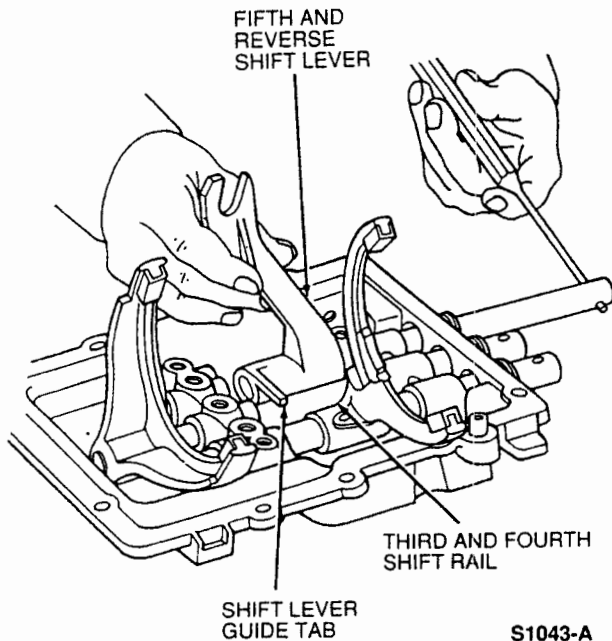

9. Install three shift interlock ball bearings.
10. Install three shift interlock springs.
11. Install shift interlock spring support cover and bolts. Tighten to 16.2 - 21.6 N•m (12-16 lb-ft) in alternating sequence.
12. Lubricate O-ring seals on shift rail guides using petroleum jelly.
13. Install shift rail guides.

NOTE: Do not twist, pinch or cut O-ring seals when installing shift rail guides.

**Shifting Lugs**

NOTE: Serviceable only as an assembly.

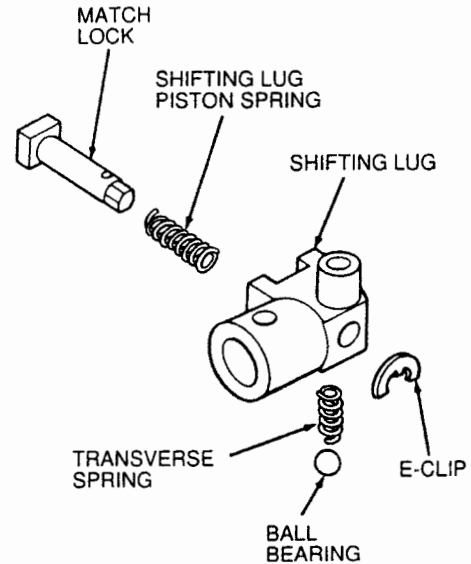

S1039-A

**DISASSEMBLY AND ASSEMBLY — SUBASSEMBLIES (CONTINUED)****Extension Housing****Disassembly and Assembly****Shift Selector Rail Assembly**

1. Early Design — Remove shift selector finger Allen screw.
2. Late Design — Remove shift selector finger roll pin with a punch
2. Slide shift selector finger off end of shift selector rail and remove shift selector finger.

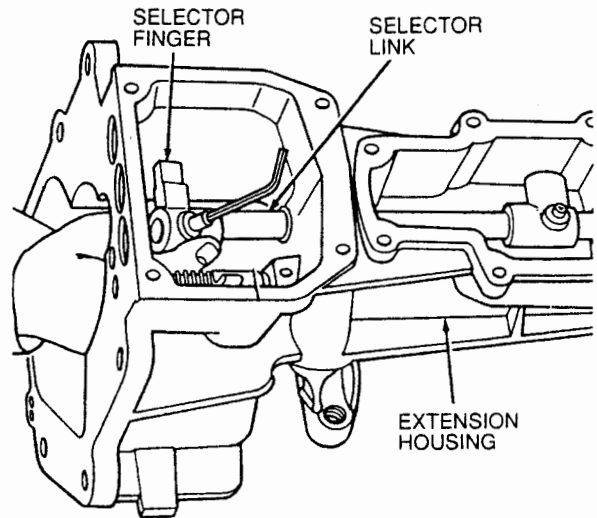

S1030-A

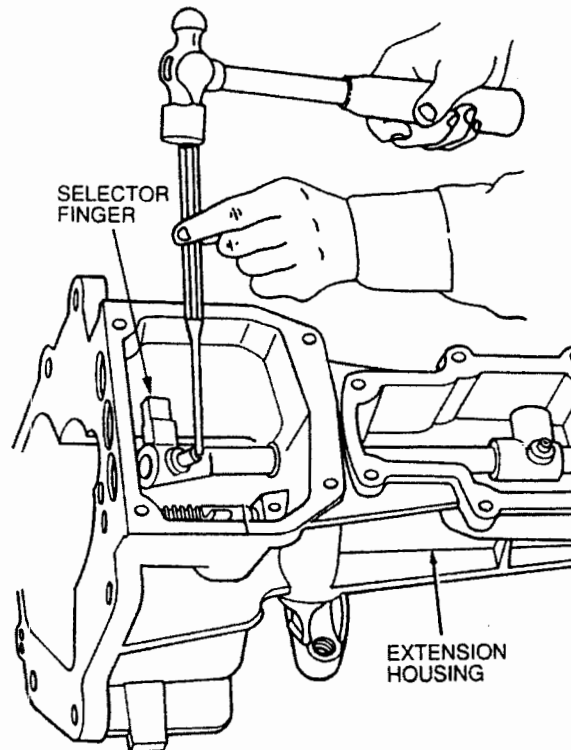
**Early Design —  
Shift Selector Finger**

S1030-A

**Late Design —  
Shift Selector Finger**

**DISASSEMBLY AND ASSEMBLY — SUBASSEMBLIES (CONTINUED)**

3. Early Design — Remove shift lever socket assembly Allen screw.

Late Design — Align roll pin with hole in the housing and remove shift lever socket assembly roll pin with a punch.

4. Hold shift lever socket assembly and slide shift selector rail out of front of extension housing assembly and shift lever socket assembly.

5. Remove shift lever socket assembly from extension housing.

**Assembly**

1. To assemble, reverse Disassembly procedure.

Early Design — Tighten Allen screw to 13.5-19 N.m. (10-14 lb-ft).

Late Design — Install new roll pin.

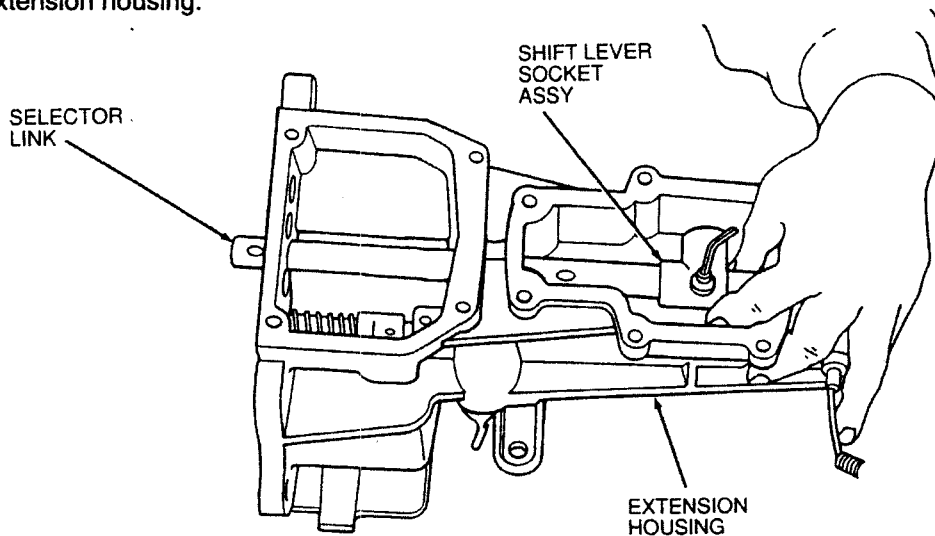
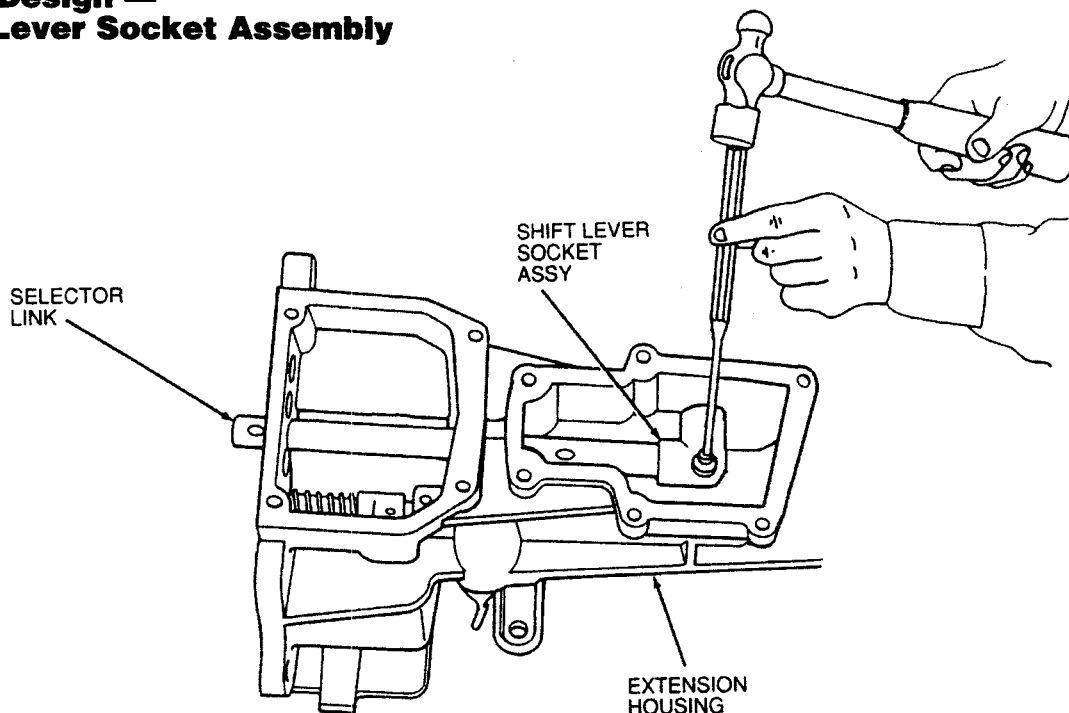
**Early Design — Shift Lever Socket Assembly****Late Design — Shift Lever Socket Assembly**



**DISASSEMBLY AND ASSEMBLY — SUBASSEMBLIES (CONTINUED)****Reverse Inhibitor Assembly**

1. Remove roll pin securing reverse inhibitor to reverse inhibitor shaft.
2. Remove Allen screw securing reverse inhibitor shaft to extension housing.
3. Slide reverse inhibitor shaft through guide hole in front of extension housing.
4. While sliding reverse inhibitor shaft out, remove reverse inhibitor and reverse inhibitor spring.

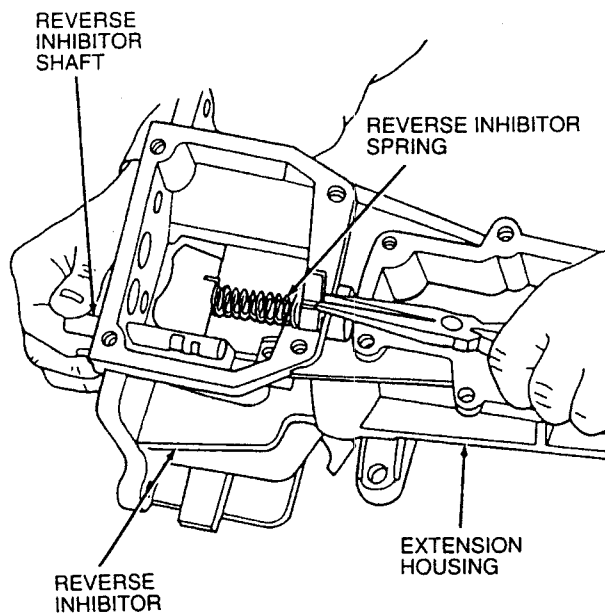

S1032-A

5. To assemble, install reverse inhibitor shaft through guide hole in extension housing.
6. While inserting reverse inhibitor shaft, position reverse inhibitor spring and reverse inhibitor properly on the shaft.

7. Continue inserting the reverse inhibitor shaft until it is properly seated in the extension housing. (Cut out areas on shaft face to the left.)
8. Install Allen screw securing reverse inhibitor shaft to extension housing. Tighten Allen screw to 9.4-12 N·m (7-9 lb-ft).
9. Install roll pin securing reverse inhibitor to the reverse inhibitor shaft.
10. Position tab on reverse inhibitor spring in the spring guide of the extension housing.

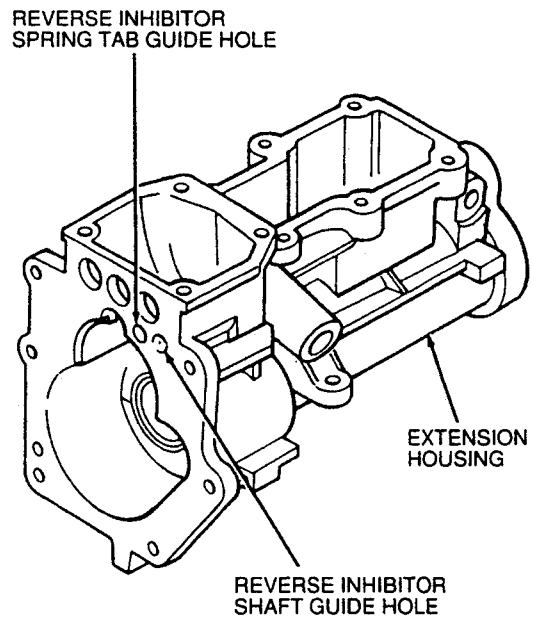

S1033-A

11. Inspect reverse inhibitor for proper movement.

**DISASSEMBLY AND ASSEMBLY — SUBASSEMBLIES (CONTINUED)**

**Extension Housing Rear Seal**

1. Remove seal from extension housing using a impact slide hammer and seal remover tool.

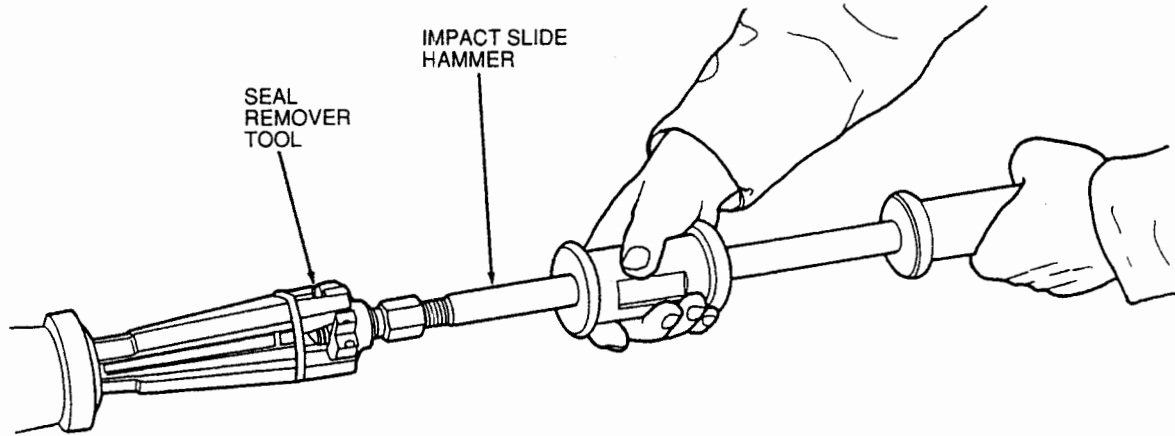

S1037-A

2. To assemble, install new extension housing rear seal using extension housing seal installer.

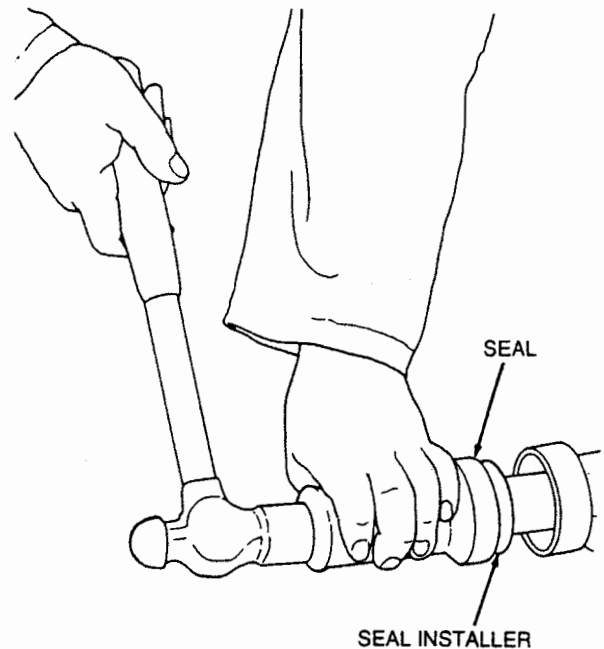

S1038-A

**ASSEMBLY — TRANSMISSION**

1. Mount transmission case to a bench-mounted holding fixture.
2. Install countershaft assembly.

**NOTE:** Make sure countershaft front bearing race is properly positioned in transmission case.

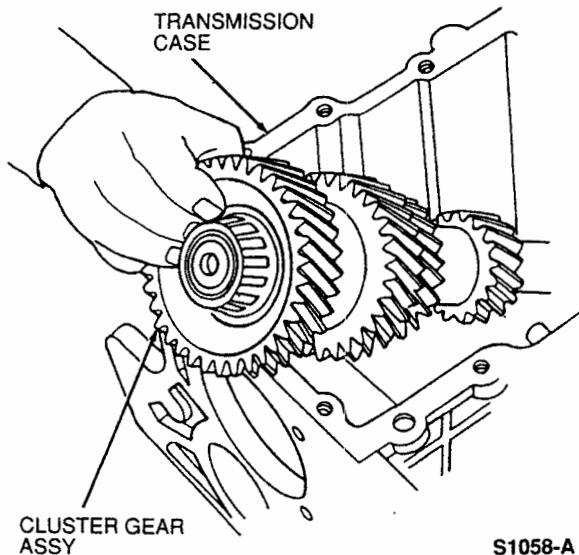

3. Install countershaft to case intermediate bearing.
4. Install reverse idler gear assembly.

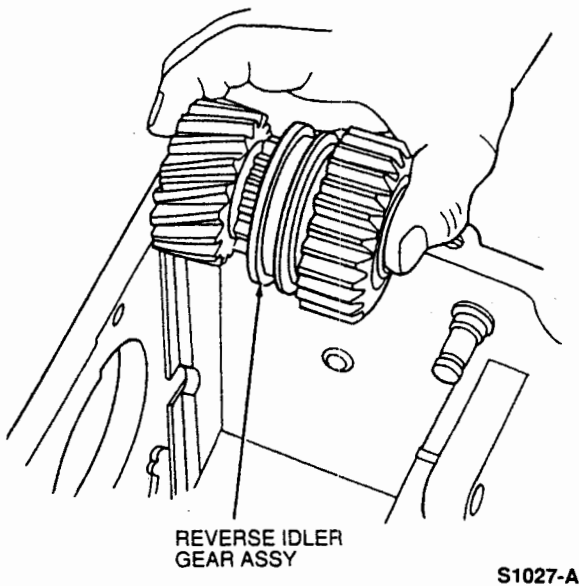

**NOTE:** Make sure locking tabs on the front and rear thrust washers are properly locked into position.

5. Install reverse idler gear shaft.

**NOTE:** Make sure shaft locking pin is properly positioned in groove in transmission case.

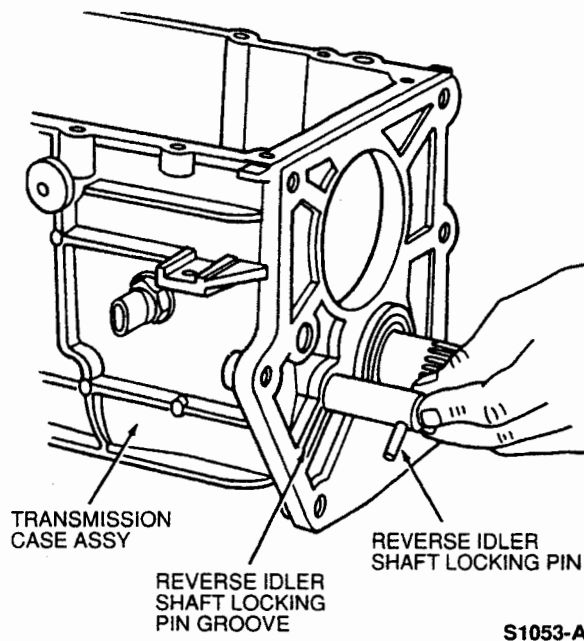

6. Rotate counter gears against reverse idler gears to ensure free movement and proper gear mesh.
7. Install fifth gear assembly without shift fork.
8. Install countershaft rear bearing.

**NOTE:** Make sure countershaft rear bearing race is installed in extension housing. For initial measurements, do not install any shims removed during disassembly.

9. Install extension housing.

**NOTE:** Do not apply anaerobic sealant. Tighten to 56.9-67.7 N·m (42-50 lb-ft).

## ASSEMBLY — TRANSMISSION (CONTINUED)

10. Measure countershaft end play using universal dial indicator. (0.000-0.004 inch.)

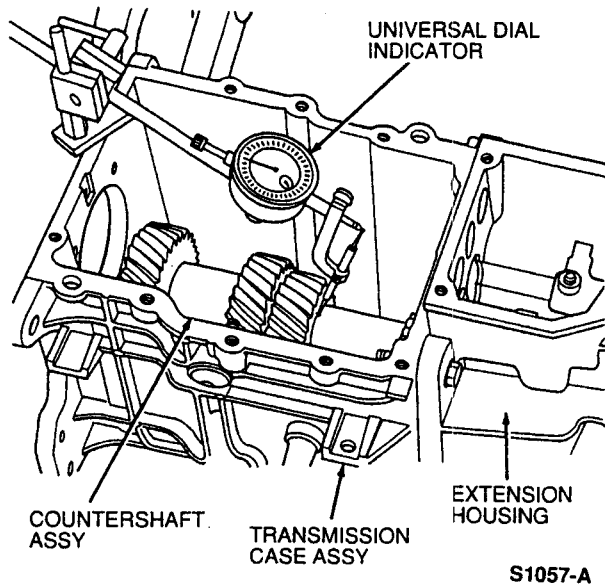

**CAUTION: If proper shims are not selected and proper end play specification is not obtained, damage to transmission may occur.**

11. Select shims required.
12. Remove extension housing and fifth gear synchronizer. Install shims with thickest shim closest to countershaft bearing race.

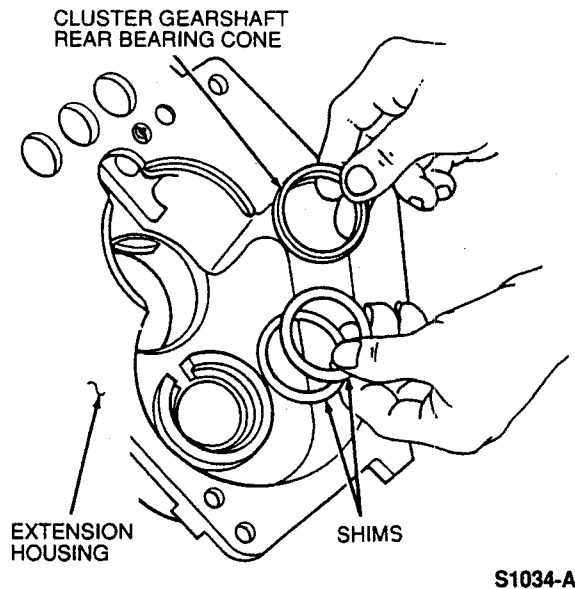

13. With new shims in position, repeat Steps 8 through 10. If end play is within specification go to Step 14.

**CAUTION: Make sure countershaft rotates freely.**

14. Install fifth and reverse selector link and retaining clip (E-clip).

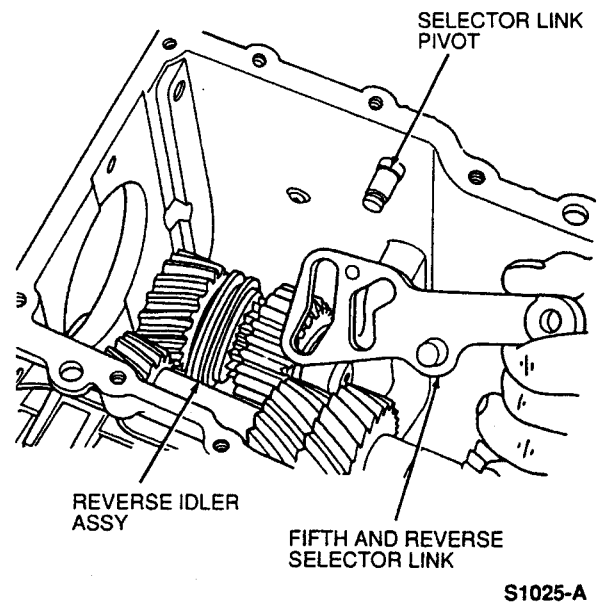

15. Install reverse shift fork.

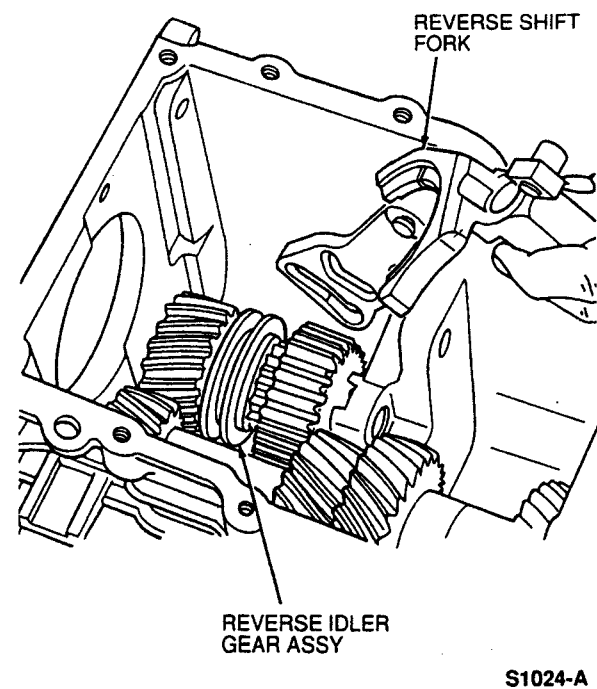

**ASSEMBLY — TRANSMISSION (CONTINUED)**

- 16. Install fifth and reverse shift rail through opening in case, through shift fork and into slot in front of case.

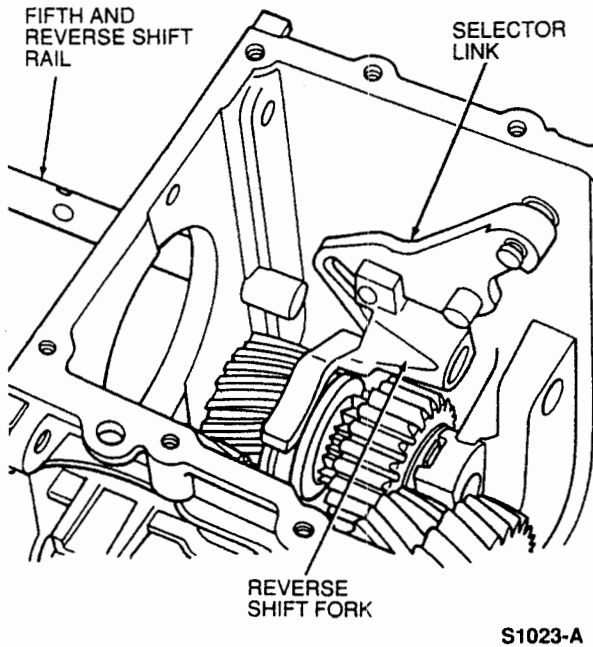

S1023-A

- 17. Install shift rail selector link pin into shift rail and rotate into position.

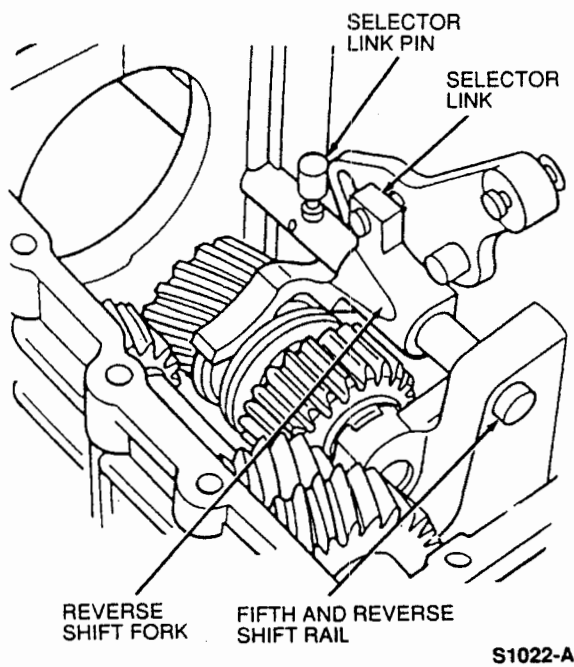

S1022-A

- 18. Install roll pin securing selector pin to shaft.

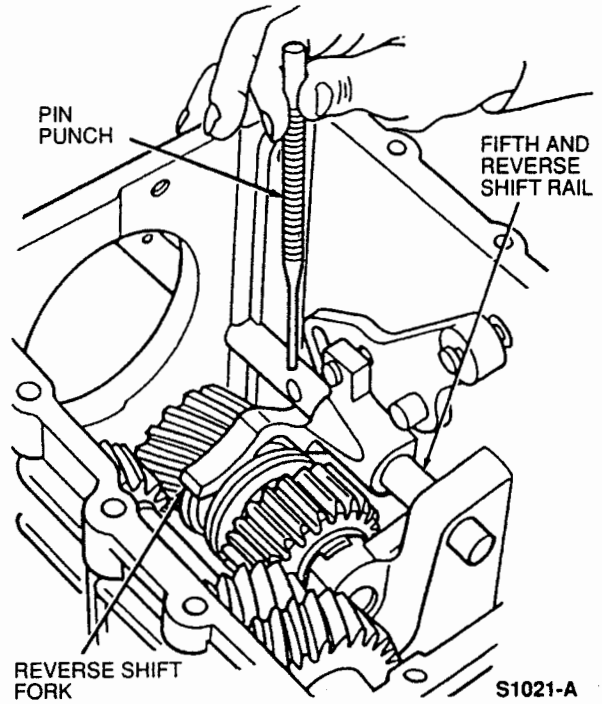

S1021-A

- 19. Install output shaft assembly.

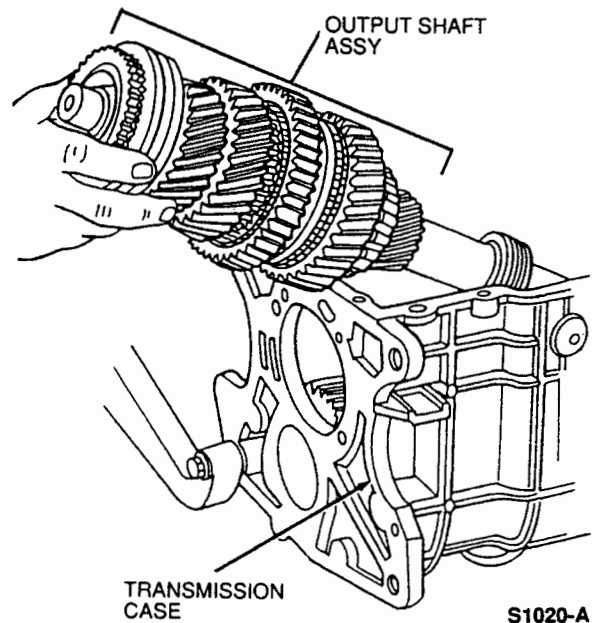

S1020-A

**ASSEMBLY — TRANSMISSION (CONTINUED)**

20. Install input shaft through front bearing bore.

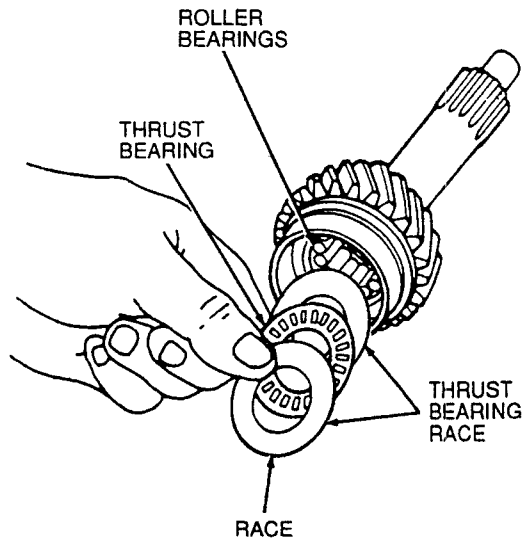

S1062-A

**NOTE:** Ensure 17 roller bearings, roller thrust bearing and race are properly positioned.

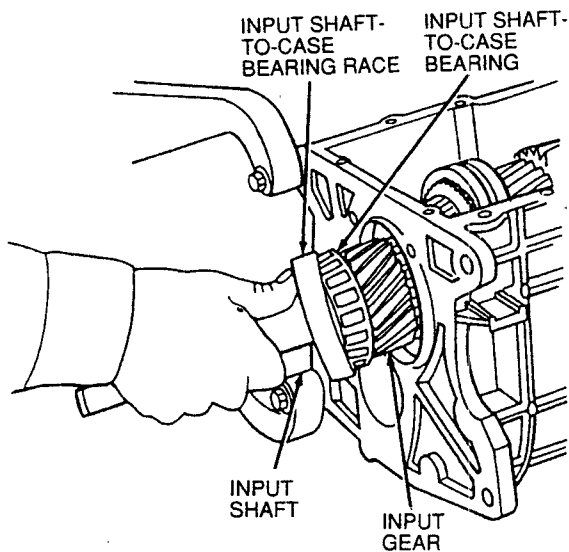

S1019-A

21. Mate splines in input shaft with splines in fourth gear clutching ring.  
 22. Install output shaft rear bearing race.  
 23. Install input shaft bearing race.  
 24. Install front bearing retainer.

**NOTE:** Make sure front bearing race is properly installed in bearing retainer. Do not apply anaerobic sealant and do not install shims. Tighten front bearing retainer bolts to 16.2-21.6 N·m (12-16 lb-ft).

25. Install extension housing and tighten bolts to 56.9-67.7 N·m (42-50 lb-ft).  
 26. Measure input shaft end play using universal dial indicator (0.000-0.004 inch).

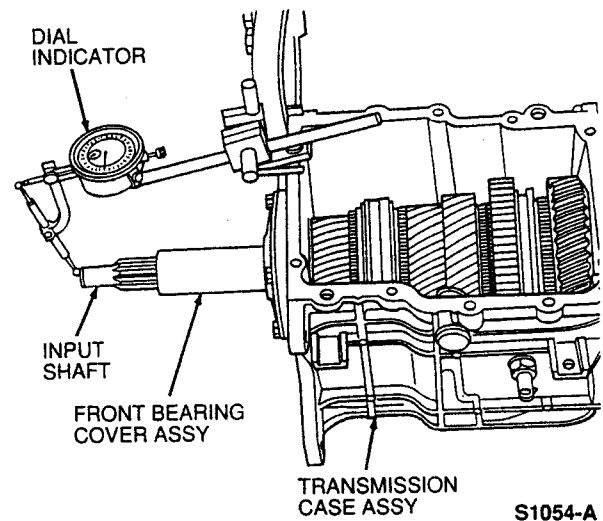

S1054-A

**CAUTION:** If proper shims are not selected and proper end play specification is not obtained, damage to transmission may occur.

**ASSEMBLY — TRANSMISSION (CONTINUED)**

27. Select shims required.
28. Remove front bearing retainer.
29. Install shims with thickest shim closest to bearing race.

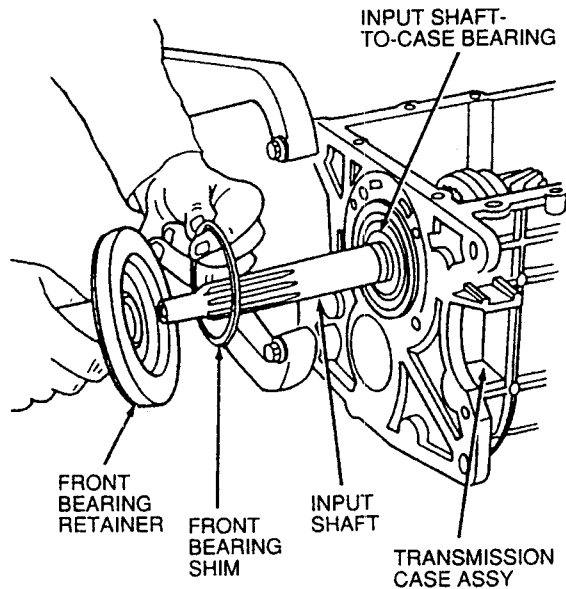

S1018-A

30. With new shims in place, repeat Step 26. If end play is within specification, go to Step 31.

**CAUTION: Make sure main shaft assembly rotates freely.**

31. Apply anaerobic sealant to mating surface of front bearing retainer and front bearing retainer bolts.

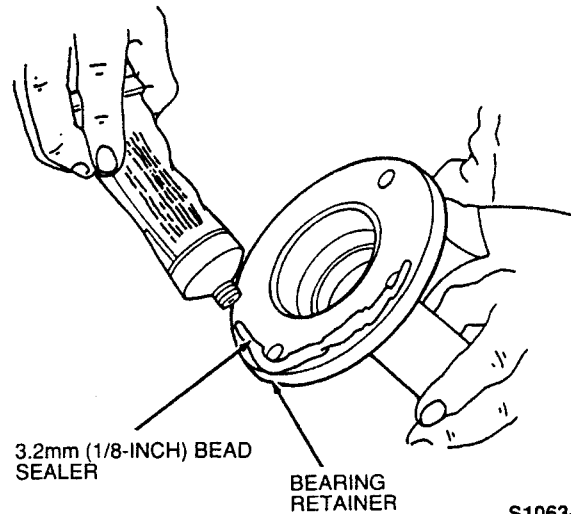

S1063-A

32. Install front bearing retainer. Tighten bolts to 16.2-21.6 N•m (12-16 lb-ft).
33. Install steel ball into hole located in rear of countershaft.
34. Install thrust washer on countershaft.
35. Install fifth gear synchronizer assembly.

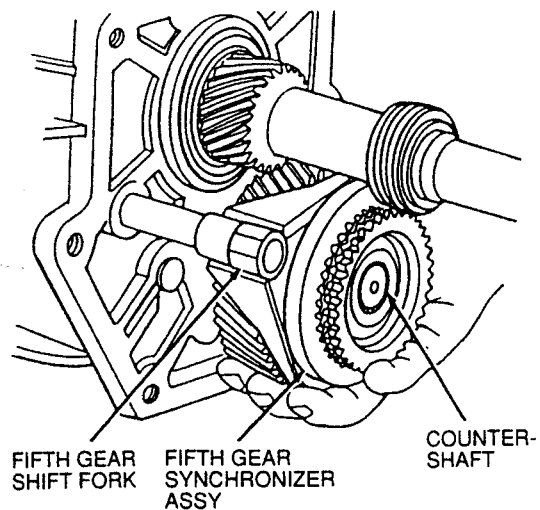

S1013-A

**ASSEMBLY — TRANSMISSION (CONTINUED)**

NOTE: Install fifth gear shift fork with synchronizer as an assembly.

- 36. Install fifth gear shift fork roll pin.
- 37. Measure first, second and third gear end play (0.000-0.016 inch, 0.018 inch maximum) using universal dial indicator (reference only).

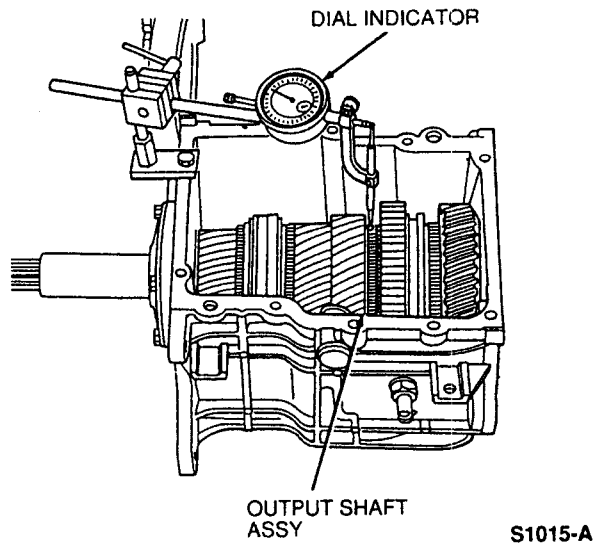

- 38. Measure gear backlash on first, second and third gears using universal dial indicator (0.000-0.016 inch) (reference only).

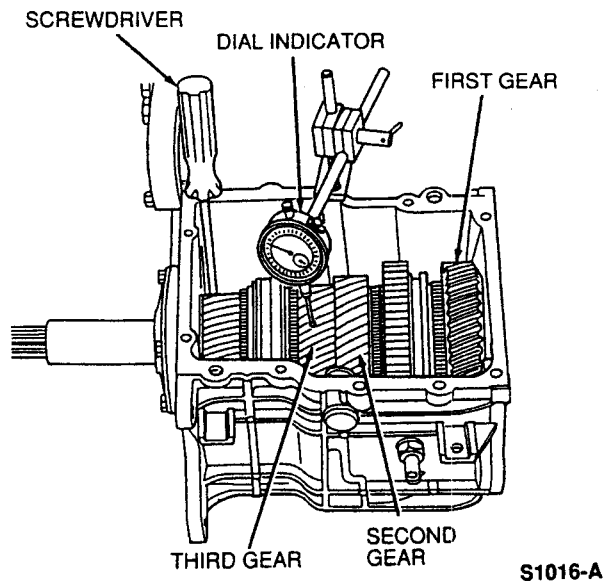

- 39. Make sure all synchronizers are in NEUTRAL position.
- 40. Apply proper coat of anaerobic sealant to transmission case, cover-to-case mating surface and bolts.
- 41. Install transmission case cover and shifting mechanism.

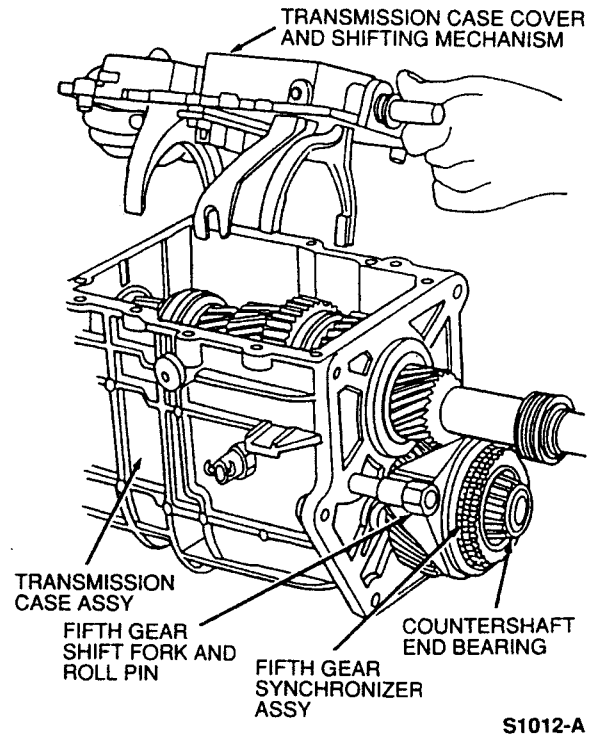

- 42. Install 10 transmission case-to-cover bolts. Tighten to 24.4-29.8 N·m (18-22 lb-ft) using proper tightening sequence.

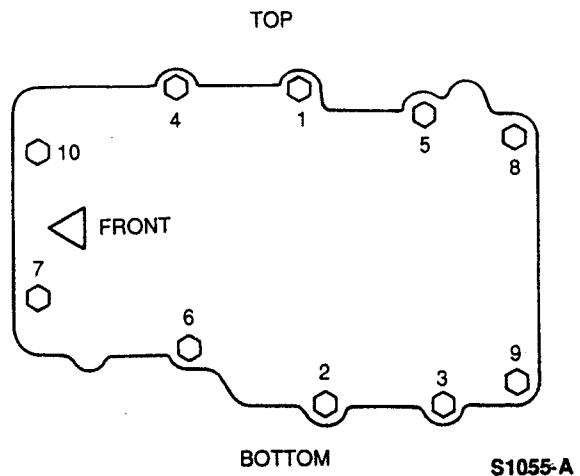



**ASSEMBLY — TRANSMISSION (CONTINUED)**

- 43. Lubricate shift rail guide O-rings.
- 44. Apply proper coat of anaerobic sealant to extension housing and extension housing bolts.
- 45. Install extension housing.

**CAUTION: Do not pinch or cut O-ring seals on shift rail guides when installing extension housing.**

- 46. Install extension housing bolts. Tighten to 56.9-67.7 N·m (42-50 lb-ft) using proper sequence.

**NOTE:** Transmission identification tag attached to top bolt on RH side.

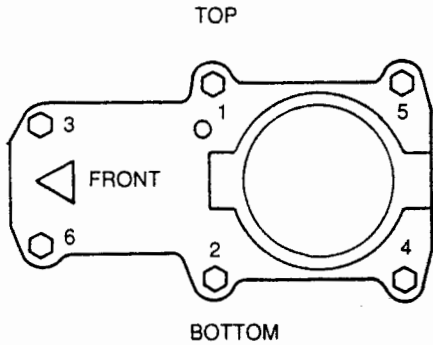

S1056-A

- 47. Rotate selector rail shift link to the left.
- 48. Install third and fourth shifting lug and secure with roll pin.

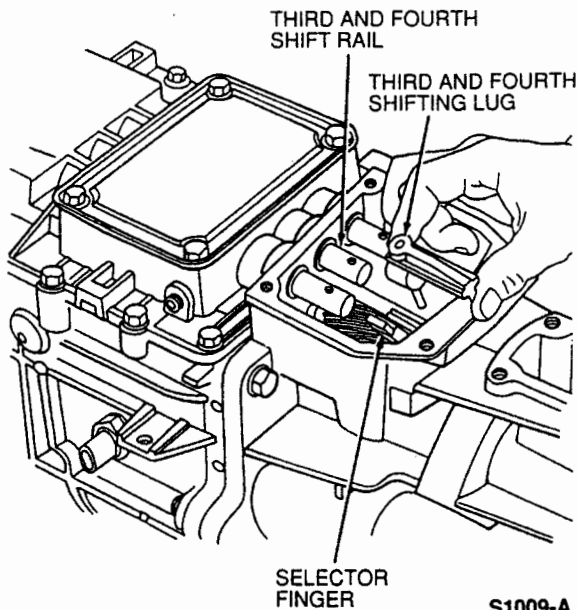

S1009-A

- 49. Install first and second shifting lug and secure with roll pin.

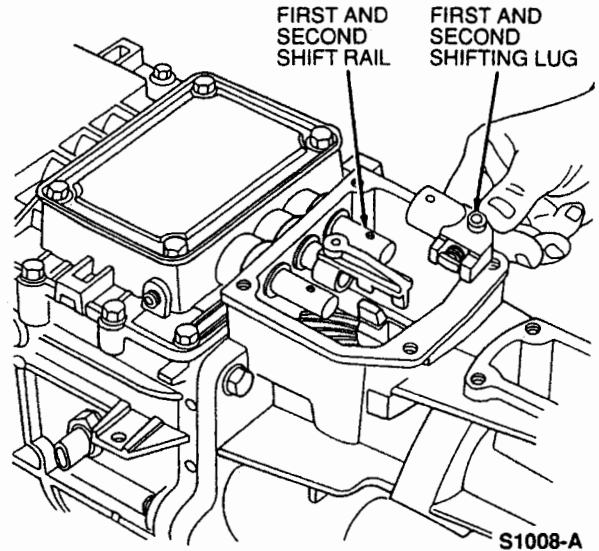

S1008-A

- 50. Rotate selector shift rail into position and install fifth and reverse shifting lug. Secure with roll pin.

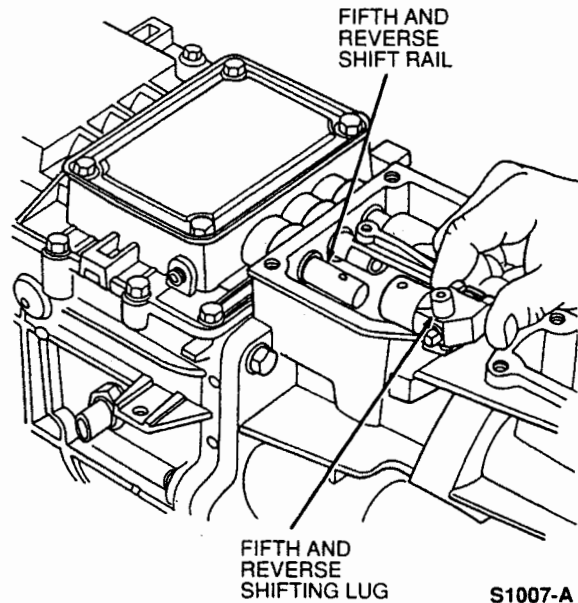

S1007-A

**ASSEMBLY — TRANSMISSION (CONTINUED)**

- 51. Ensure shifter ball socket bushing is installed.
- 52. Apply proper coat of anaerobic sealant to the mating surface of the shift turret and shift turret bolts.
- 53. Install shift lever turret assembly.  
  
NOTE: Check position of shift lever. Flat side to the right.
- 54. Install shift turret bolts. Tighten to 24.4-29.8 N•m (18-22 lb-ft) in proper sequence.

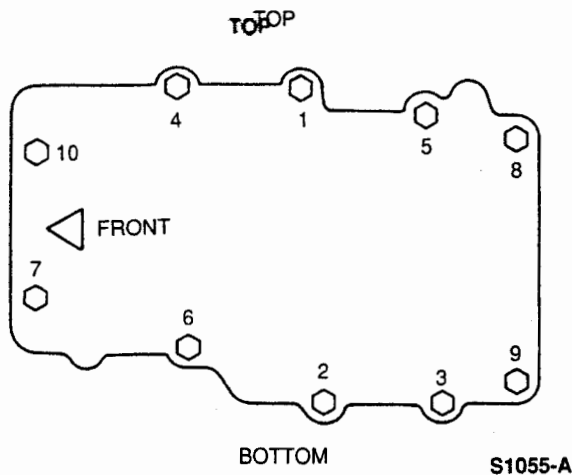

- 55. Apply proper coat of RTV sealant to both inspection covers.
- 56. Apply anaerobic sealant to inspection cover bolts.
- 57. Install inspection covers. Tighten inspection cover bolts to 16.2-21.6 N•m (12-16 lb-ft).
- 58. Apply proper coat of anaerobic sealant to drain plug and install drain plug. Tighten to 13.5-27.1 N•m (10-20 lb-ft).
- 59. Fill transmission with 3 quarts of GM Synchronesh transmission fluid (GM part no. 12345349).
- 60. Apply proper coat of anaerobic sealant to fill plug and install fill plug. Tighten to 13.5-27.1 N•m (10-20 lb-ft).
- 61. Re-install transmission as outlined.

**TRANSMISSION DIAGNOSIS**

CONDITION	POSSIBLE SOURCE	ACTION
<ul style="list-style-type: none"> <li>• Transmission Shifts Hard.</li> </ul>	<ul style="list-style-type: none"> <li>• Improper clutch release.</li> <li>• Internal shift mechanism binding.</li> <li>• Sleeve to hub fit.</li> <li>• Binding condition between input shaft and crankshaft pilot bearing.</li> <li>• Improper fluid.</li> </ul>	<ul style="list-style-type: none"> <li>• Correct condition as instructed by manufacturer.</li> <li>• Remove transmission and free up shift mechanism.</li> <li>• Remove and check for burrs or fit.</li> <li>• Check alignment and service as required.</li> <li>• Drain and refill with GM Synchronesh Transmission Fluid, 12345349, to bottom of filler plug hole.</li> </ul>
<ul style="list-style-type: none"> <li>• Gears Clash When Shifting from One Forward Gear to Another.</li> </ul>	<ul style="list-style-type: none"> <li>• Engine idle speed too high.</li> <li>• Improper clutch release.</li> <li>• Binding condition between transmission input shaft and crankshaft pilot bushing.</li> <li>• Worn or damaged shifter forks, synchronizer assembly, or gear clutch teeth.</li> </ul>	<ul style="list-style-type: none"> <li>• Adjust engine idle speed.</li> <li>• Ensure complete clutch release.</li> <li>• Remove transmission and replace pilot bushing.</li> <li>• Service or replace as required.</li> </ul>

**TRANSMISSION DIAGNOSIS — (CONTINUED)**

CONDITION	POSSIBLE SOURCE	ACTION
<ul style="list-style-type: none"> <li>• Transmission jumps out of gear.</li> </ul>	<ul style="list-style-type: none"> <li>• Floor shift — stiff or improperly installed boot.</li> <li>• Floor shift — interference between shift handle and console.</li> <li>• Transmission to engine mounting loose.</li> <li>• Flywheel housing to engine crankshaft out of alignment.</li> <li>• Improper engagement between transmission pilot and flywheel housing.</li> <li>• Input shaft pilot bearing worn.</li> <li>• Worn or damaged internal components.</li> </ul>	<ul style="list-style-type: none"> <li>• Verify jump-out with boot removed. Replace boot if necessary.</li> <li>• Adjust console to eliminate interference.</li> <li>• Tighten bolts to specification.</li> <li>• Replace parts as required.</li> <li>• Replace parts as required.</li> <li>• Replace pilot bearing.</li> <li>• Check input and output shafts for excessive end play, shift forks for loose mounting of shift rails, worn pads, shift rail detent system for wear or damage, synchronizer sliding sleeve and gear clutch teeth for wear or damage. Service or replace as required.</li> </ul>
<ul style="list-style-type: none"> <li>• Transmission will not shift into one gear — all other gears OK.</li> </ul>	<ul style="list-style-type: none"> <li>• Floor shift, interference between shift handle and console or floor cut out.</li> <li>• Restricted travel of internal shifter components.</li> </ul>	<ul style="list-style-type: none"> <li>• Adjust console or cut out floorpan to eliminate interference.</li> <li>• Remove transmission. Inspect shift rail and fork system, synchronizer system and gear clutch-teeth for restricted travel. Service and replace as required.</li> </ul>
<ul style="list-style-type: none"> <li>• Transmission is locked in one gear. It cannot be shifted out of that gear.</li> </ul>	<ul style="list-style-type: none"> <li>• Internal shifter components worn or damaged.</li> <li>• Selector arm finger broken.</li> <li>• Bent shifter forks at pads and selector slot.</li> </ul>	<ul style="list-style-type: none"> <li>• Remove transmission. Inspect the problem gear or gear shift rails and fork and synchronizer for wear or damage. Service or replace as required.</li> <li>• Remove transmission. Replace selector arm assembly.</li> <li>• Service or replace as required.</li> </ul>
<ul style="list-style-type: none"> <li>• Transmission will not shift into reverse (All others OK).</li> </ul>	<ul style="list-style-type: none"> <li>• Worn or damaged internal components.</li> </ul>	<ul style="list-style-type: none"> <li>• Remove transmission. Check for damaged reverse gear train, misaligned reverse relay lever, shift rail and fork system. Service or replace as required.</li> </ul>

**TRANSMISSION DIAGNOSIS — (CONTINUED)**

CONDITION	POSSIBLE SOURCE	ACTION
<ul style="list-style-type: none"> <li>• Transmission noisy in gear.</li> </ul>	<ul style="list-style-type: none"> <li>• Lubricant level low or wrong type.</li> <li>• Transmission to flywheel housing and flywheel housing to engine block bolts loose.</li> <li>• Pilot bushing worn or damaged.</li> <li>• Improper transmission pilot engagement into flywheel housing.</li> <li>• Worn or damaged internal components.</li> </ul>	<ul style="list-style-type: none"> <li>• Fill to bottom of filler plug hole with proper lubricant.</li> <li>• Tighten bolts to specification.</li> <li>• Remove transmission. If noise is howl during start-up, check pilot bushing. Check for loose flywheel and housing alignment. Service or replace as required.</li> <li>• Replace housing or input shaft bearing retainer as required.</li> <li>• Disassemble transmission. Inspect input, output and countershaft bearings, gear and gear teeth for wear or damage. Service or replace as required.</li> </ul>
<ul style="list-style-type: none"> <li>• Transmission leaks.</li> </ul>	<ul style="list-style-type: none"> <li>• Excessive amount of lubricant in transmission — wrong type.</li> <li>• Other component(s) leaking.</li> <li>• False report.</li> <li>• Worn or damaged internal components.</li> <li>• Inadequate thread sealant on threads.</li> </ul>	<ul style="list-style-type: none"> <li>• Check level and type. Fill to bottom of filler plug hole.</li> <li>• Identify leaking fluid at engine, power steering and/or transmission.</li> <li>• Remove all traces of lubricant on exposed transmission surfaces. Check vent for free breathing. Operating transmission and inspect for new leakage. Service as required.</li> <li>• Remove transmission. Inspect for leaks at the input shaft bearing retainer seal and gasket, top cover gasket. Inspect case for sand holes. Service or replace as required.</li> <li>• Apply proper sealant to bolt threads.</li> </ul>

**INSPECTION**

1. Inspect transmission case for cracks, worn or damaged bearing bores, damaged threads, or any other damage that could affect operation of the transmission.
2. Inspect the front face of the case for small nicks or burrs that could cause misalignment of the transmission with the flywheel housing. Remove all small nicks or burrs with a fine file.
3. Replace any cover that is bent or distorted. Make sure that the vent hole in the turret is open.
4. Check the condition of the shift levers, forks, shift rails, and the lever and shafts.
5. Inspect the bearings.
6. Replace roller bearings that are broken, worn or rough, and check their respective races.
7. Replace the countershaft (cluster) gear if the teeth are chipped, broken or worn. Replace the countershaft if it is bent, scored or worn.
8. Replace the reverse idler gear or sliding gear if the teeth are chipped, worn or broken. Replace the idler gear shaft if bent, worn or scored.
9. Replace the input shaft and gear if the splines are damaged or if the teeth are chipped, worn or broken. If the roller bearing surface in the bore of the gear is worn or rough, or if the cone surface is damaged, replace the gear and gear rollers.
10. Replace all other gears that are chipped, broken or worn.
11. Check the synchronizer sleeves for free movement on their hubs. Make sure that the alignment marks (if present) are properly indexed.
12. Inspect the synchronizer blocking rings for widened index slots, rounded clutch teeth, and smooth internal surfaces (must have machined grooves). With the blocker ring on the cone, the distance between the face of the blocker ring and the clutch teeth on the gear must not be less than 0.50mm (0.020 inch).
13. Replace speedometer drive gear if teeth are stripped or damaged. Make certain to install correct size replacement gear.

14. Replace the output shaft if there is any evidence of wear or if any of the splines are damaged.
15. Inspect bushing and seal in the extension housing and replace seal. Replace extension housing if bushing is worn or damaged.
16. Replace the seal in the input shaft bearing retainer.

**TRANSMISSION CLEANING**

1. Wash all parts except bearings, O-rings and seals in a suitable cleaning solvent. Brush or scrape all foreign matter from the parts. Be careful not to damage any parts with the scraper.  
**CAUTION: Do not clean, wash or soak transmission seals in cleaning solvents. Dry all parts with compressed air.**
2. Rotate bearings in a cleaning solvent until all lubricant is removed. Hold bearing assembly to prevent it from rotating and dry it with compressed air.
3. Lubricate bearings with petroleum jelly and wrap them in a clean, lint-free cloth or paper until ready for use.
4. Clean the magnet in the bottom of the case with kerosene or mineral spirits.

**SPECIFICATIONS****Sealant Specifications**

Anaerobic Sealant	ET-M29
RTV Sealant	Loctite® 493
Grease for Needle Bearings	ET-M11

**Oil Capacity**

3 quarts of GM Synchronesh transmission fluid (GM part no. 12345349)

**Torque Specifications**

Description	N-m	Lb-Ft
Allen Screws	13.5-19	10-14
Sensors	16.2-21.6	12-16
Backup Lamp Switch	16.2-21.6	12-16
Inspection Cover Bolts	16.2-21.6	12-16
Turret Shifter Pin Bolts	16.2-21.6	12-16
Spring Interlock Bracket Bolts	16.2-21.6	12-16
Case Cover Bolts	24.4-29.8	18-22
Shift Turret Bolts	24.4-29.8	18-22
Extension Housing Bolts	56.9-67.7	42-50
Fill Plug	13.5-27.1	10-20
Drain Plug	13.5-27.1	10-20
Front Bearing Retainer Bolts	16.2-21.6	12-16
Reverse Inhibitor Allen Screw	9.4-12	7-9

Model	Gear Ratios						Torque	No. of Teeth	
	1st	2nd	3rd	4th	5th	Rev.	Lb-Ft	Input Shaft	Output Shaft
3550	3.27	1.98	1.34	1.00	.068	3.00	350	10	28
TKO	3.27	1.98	1.34	1.00	.068	3.00	375	26	31

## INTRODUCTION

Most threaded fasteners are covered by specifications that define required mechanical properties, such as tensile strength, yield strength, proof load and hardness. These specifications are carefully considered in initial selection of fasteners for a given application. To ensure continued satisfactory vehicle performance, replacement fasteners used should be of the correct strength, as well as the correct nominal diameter, thread pitch, length, and finish.

Most original equipment fasteners (English or Metric system) are identified with markings or numbers indicating the strength of the fastener. These markings are described in the pages that follow. Attention to these markings is important to ensure that the proper replacement fasteners are used.

Further, some metric fasteners, especially nuts, are colored blue. This metric blue identification is in most cases a temporary aid for production start-up, and color will generally revert to normal black or bright after start-up.

## NOMENCLATURE FOR BOLTS

### ENGLISH SYSTEM Bolt, 1/2-13x1

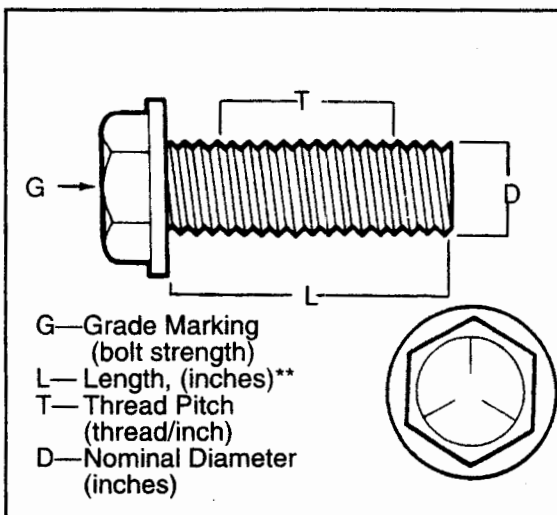

### METRIC SYSTEM Bolt, M12-1.75x25

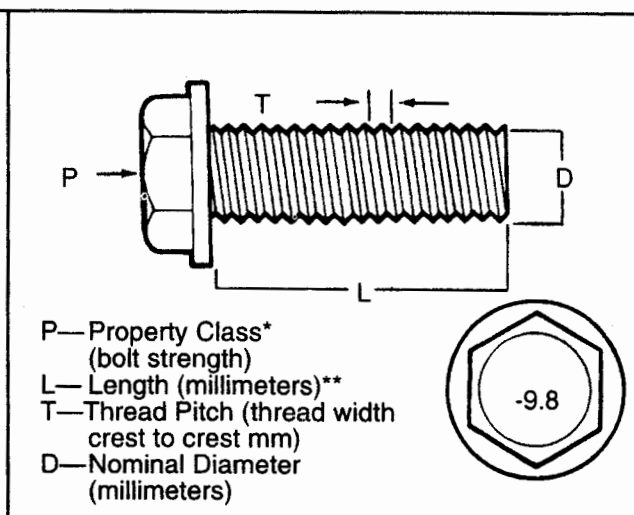

\*The property class is an Arabic numeral distinguishable from the slash SAE English grade system.

\*\*The length of all bolts is measured from the underside of the head to the end.

**BOLT STRENGTH IDENTIFICATION**

**ENGLISH SYSTEM**

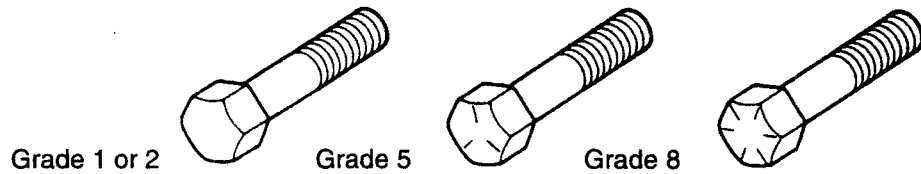

**English (Inch) bolts:** Identification marks correspond to bolt strength; increasing number of slashes represent increasing strength.

**METRIC SYSTEM**

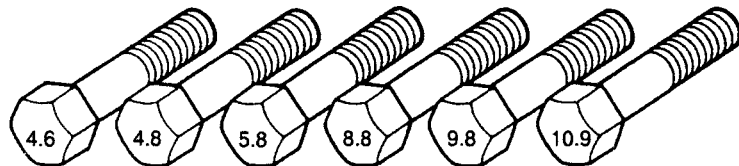

**Metric bolts:** Identification class numbers correspond to bolt strength; increasing numbers represent increasing strength. Common metric fastener bolt strength property are 9.8 and 10.9 with the class identification embossed on the bolt head.

**HEX NUT STRENGTH IDENTIFICATION**

**ENGLISH SYSTEM**

**METRIC SYSTEM**

Grade	Hex Nut Grade 5	Hex Nut Grade 8	Class	Hex Nut Property Class 9	Hex Nut Property Class 10
Identification			Identification		
	3 Dots	6 Dots		Arabic 9	Arabic 10
Increasing dots represent increasing strength.			May also have blue finish or paint daub on hex flat. Increasing numbers represent increasing strength.		

**OTHER TYPES OF PARTS**

Metric identification schemes vary by type of part, most often a variation of that used of bolts and nuts. Note that many types of English and Metric fasteners carry no special identification if they are otherwise unique.

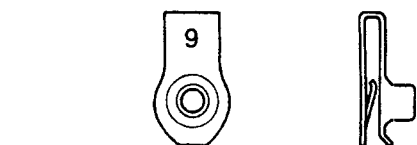

— Stamped U-Nuts.

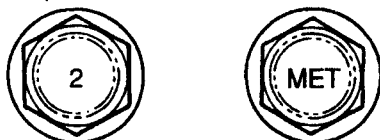

— Tapping, thread forming and certain other case hardened screws.

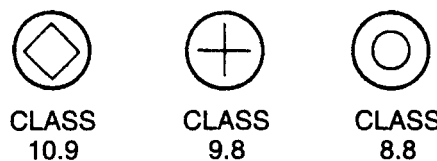
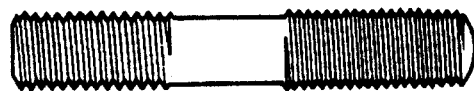

— Studs, large studs may carry the property class number. Smaller studs use a geometric code on the end.



## ENGLISH/METRIC CONVERSION

DESCRIPTION	MULTIPLY	BY	FOR METRIC EQUIVALENT
Acceleration	foot/sec <sup>2</sup>	0.3048	metre/sec <sup>2</sup> (m/s <sup>2</sup> )
	inch/sec <sup>2</sup>	0.0254	metre/sec <sup>2</sup>
Torque	pound-inch	0.11298	newton-metres (N•m)
	pound-foot	1.3558	newton-metres
Power	horsepower	0.746	kilowatts (kw)
Pressure or Stress	inches of water	0.2491	kilopascals (kPa)
	pounds/sq. in.	6.895	kilopascals (kPa)
	pounds/sq. in.	0.069	bar
Energy or Work	BTU	1,055.0	joules (J)
	pound-foot	1.3558	joules (J)
	kilowatt-hour	3,600,000.	joules (J = one W•s)
		or 3.6 x 10 <sup>6</sup>	
Light	foot candle	10.764	lumens/metre <sup>2</sup> (lm/m <sup>2</sup> )
Fuel Performance	miles/gal	0.4251	kilometres/litre (km/l)
	gal/mile	2.3527	litres/kilometre (l/km)
Velocity	miles/hour	1.6093	kilometres/hr. (km/h)
Length	inch	25.4	millimetres (mm)
	foot	0.3048	metres (m)
	yard	0.9144	metres (m)
	mile	1.609	kilometres (km)
Area	inch <sup>2</sup>	645.2	millimetres <sup>2</sup> (mm <sup>2</sup> )
		6.45	centimetres <sup>2</sup> (cm <sup>2</sup> )
	foot <sup>2</sup>	0.0929	metres <sup>2</sup> (m <sup>2</sup> )
	yard <sup>2</sup>	0.8361	metres <sup>2</sup>
Volume	inch <sup>3</sup>	16,387.0	mm <sup>3</sup>
		16.387	cm <sup>3</sup>
		0.0164	litres (l)
	quart	0.9464	litres
	gallon	3.7854	litres
	yard <sup>3</sup>	0.7646	metres <sup>3</sup> (m <sup>3</sup> )
Mass	pound	0.4536	kilograms (kg)
	ton	907.18	kilogram (kg)
	ton	0.90718	tonne (t)
Force	kilogram	9.807	newtons (N)
	ounce	0.2780	newtons
	pound	4.448	newtons
Temperature	degree fahrenheit (°F)	(°F -32) 0.556	degree Celsius (°C)

## DECIMAL AND METRIC EQUIVALENTS

FRACTIONS	DECIMAL INCH	METRIC MM
1/64	.015625	.397
1/32	.03125	.794
3/64	.046875	1.191
1/16	.0625	1.588
5/64	.078125	1.984
3/32	.09375	2.381
7/64	.109375	2.778
1/8	.125	3.175
9/64	.140625	3.572
5/32	.15625	3.969
11/64	.171875	4.366
3/16	.1875	4.763
13/64	.203125	5.159
7/32	.21875	5.556
15/64	.234375	5.953
1/4	.250	6.35
17/64	.265625	6.747
9/32	.28125	7.144
19/64	.296875	7.54
5/16	.3125	7.938
21/64	.328125	8.334
11/32	.34375	8.731
23/64	.359375	9.128
3/8	.375	9.525
25/64	.390625	9.922
13/32	.40625	10.319
27/64	.421875	10.716
7/16	.4375	11.113
29/64	.453125	11.509
15/32	.46875	11.906
31/64	.484375	12.303
1/2	.500	12.7

FRACTIONS	DECIMAL INCH	METRIC MM
33/64	.515625	13.097
17/32	.53125	13.494
35/64	.546875	13.891
9/16	.5625	14.288
37/64	.578125	14.684
19/32	.59375	15.081
39/64	.609375	15.478
5/8	.625	15.875
41/64	.640625	16.272
21/32	.65625	16.669
43/64	.671875	17.066
11/16	.6875	17.463
45/64	.703125	17.859
23/32	.71875	18.256
47/64	.734375	18.653
3/4	.750	19.05
49/64	.765625	19.447
25/32	.78125	19.844
51/64	.796875	20.241
13/16	.8125	20.638
53/64	.828125	21.034
27/32	.84375	21.431
55/64	.859375	21.828
7/8	.875	22.225
57/64	.890625	22.622
29/32	.90625	23.019
59/64	.921875	23.416
15/16	.9375	23.813
61/64	.953125	24.209
31/32	.96875	24.606
63/64	.984375	25.003
1	1.00	25.4

**TORQUE CONVERSION**

NEWTON METRES (N•m)	POUND-FEET (LB-FT)
1	0.7376
2	1.5
3	2.2
4	3.0
5	3.7
6	4.4
7	5.2
8	5.9
9	6.6
10	7.4
15	11.1
20	14.8
25	18.4
30	22.1
35	25.8
40	29.5
50	36.9
60	44.3
70	51.6
80	59.0
90	66.4
100	73.8
110	81.1
120	88.5
130	95.9
140	103.3
150	110.6
160	118.0
170	125.4
180	132.8
190	140.1
200	147.5
225	166.0
250	184.4

POUND-FEET (LB-FT)	NEWTON METRES (N•m)
1	1.356
2	2.7
3	4.0
4	5.4
5	6.8
6	8.1
7	9.5
8	10.8
9	12.2
10	13.6
15	20.3
20	27.1
25	33.9
30	40.7
35	47.5
40	54.2
45	61.0
50	67.8
55	74.6
60	81.4
65	88.1
70	94.9
75	101.7
80	108.5
90	122.0
100	135.6
110	149.1
120	162.7
130	176.3
140	189.8
150	203.4
160	216.9
170	230.5
180	244.0